

نموذج رقم (1)

إقرار

أنا الموقع أدناه مقدم الرسالة التي تحمل العنوان:

Next Generation Passive Optical Network Stage Two NG-PON2

الجيل القادم للشبكات الضوئية - المرحلة الثانية

أقر بأن ما اشتملت عليه هذه الرسالة إنما هو نتاج جهدي الخاص، باستثناء ما تمت الإشارة إليه حيثما ورد، وإن هذه الرسالة ككل أو أي جزء منها لم يقدم من قبل لنيل درجة أو لقب علمي أو بحثي لدى أي مؤسسة تعليمية أو بحثية أخرى.

DECLARATION

The work provided in this thesis, unless otherwise referenced, is the researcher's own work, and has not been submitted elsewhere for any other degree or qualification

Student's name:

اسم الطالب: محمد أحمد محمد العايدي

Signature:

التوقيع: 

Date:

التاريخ: 2014/10/10

The Islamic University – Gaza
Deanery of Higher Studies
Faculty of Engineering
Dept. of Electric Engineering



Next Generation Passive Optical Network Stage Two NG-PON2

الجيل القادم للشبكات الضوئية – المرحلة الثانية

A Thesis Presented by:

Mohammed Ahmed Elaydi

Supervised by:

Dr. Fady El-Nahal

A Thesis Submitted to IUG In Fulfillment of the Requirements for the Degree of Master
in Electrical Engineering

2014-1435



نتيجة الحكم على أطروحة ماجستير

بناءً على موافقة شئون البحث العلمي والدراسات العليا بالجامعة الإسلامية بغزة على تشكيل لجنة الحكم على أطروحة الباحث/ محمد أحمد محمد العايدي لنيل درجة الماجستير في كلية الهندسة / قسم الهندسة الكهربائية - أنظمة الاتصالات وموضوعها:

الجيل القادم لشبكات الألياف الضوئية المرحلة الثانية

Next Generation Passive Optical Network Stage Two NG-PON2

وبعد المناقشة التي تمت اليوم الثلاثاء 28 ذو القعدة 1435هـ، الموافق 2014/09/23م الساعة العاشرة والنصف صباحاً، اجتمعت لجنة الحكم على الأطروحة والمكونة من:

.....
.....
.....

د. فادي إبراهيم النحال
د. عمار محمد أبو هروس
د. عبد الحكيم محمد حسين
مشرفاً ورئيساً
مناقشاً داخلياً
مناقشاً خارجياً

وبعد المداولة أوصت اللجنة بمنح الباحث درجة الماجستير في كلية الهندسة / قسم الهندسة الكهربائية - أنظمة الاتصالات.

واللجنة إذ تمنحه هذه الدرجة فإنها توصيه بتقوى الله ولزوم طاعته وأن يسخر علمه في خدمة دينه ووطنه.

والله ولي التوفيق ،،،

مساعد نائب الرئيس للبحث العلمي والدراسات العليا

.....
.....
.....
أ.د. فؤاد علي العاجز





سورة البقرة - الآية 269

TABLE OF CONTENTS

Contents

| | |
|--|------|
| TABLE OF CONTENTS | III |
| Contents | III |
| DEDICATION | V |
| ACKNOWLEDGMENT | VI |
| LIST OF FIGURES | VII |
| LIST OF TABLES | IX |
| Abbreviations, Acronyms, and Terms | X |
| ABSTRACT | XII |
| ملخص الدراسة..... | XIII |
| 1. Chapter 1: Introduction..... | 1 |
| 1.1. Introduction..... | 1 |
| 1.2. Background..... | 1 |
| 1.3. NG-PON | 2 |
| 1.3.1. NG-PON1 | 3 |
| 1.3.2. NG-PON2 | 4 |
| 1.4. Literature Review | 5 |
| 1.5. Research Problem..... | 5 |
| 1.6. Motivation and Objectives | 6 |
| 1.7. Methodology & Implementation | 8 |
| 1.8. Novelty aspects | 9 |
| 1.9. Outlines of Thesis | 9 |
| 2. Chapter 2: Broadband Access Networks | 10 |
| 2.1. Introduction..... | 10 |
| 2.2. The need for optical fiber in broadband access network segment..... | 11 |
| 2.3. Advantages of fiber optical cables: | 12 |
| 2.4. Optical cable wavelength Spectrum..... | 13 |
| 2.5. Optical Network Devices | 13 |
| 2.5.1. Mach-Zehnder Modulator | 14 |
| 2.5.2. Arrayed Waveguide Grating (AWG) | 14 |
| 2.6. Optical Access network topologies | 16 |
| 2.6.1. Point-to-point configuration (P2P)..... | 16 |
| 2.6.2. Point-to-multipoint configuration (P2MP) | 16 |
| 3. Chapter 3: Passive Optical Networks | 18 |
| 3.1. Introduction..... | 18 |
| 3.1.1. Optical Line Terminal (OLT) | 18 |

| | | |
|--------|--|----|
| 3.1.2. | Optical Network Terminal ONT | 20 |
| 3.1.3. | Optical Splitter | 20 |
| 3.2. | Advantages of PON | 21 |
| 3.3. | PON standards | 22 |
| 3.3.1. | APON / BPON | 24 |
| 3.3.2. | Ethernet PON | 26 |
| 3.3.3. | Gigabit PON | 27 |
| 3.3.4. | WDM PON | 28 |
| 3.3.5. | NG-PON | 28 |
| 4. | Chapter 4: Designing of a TWDM NG-PON2 | 31 |
| 4.1. | Introduction | 31 |
| 4.2. | Key Technology | 31 |
| 4.2.1. | Tuneable Transmitter | 32 |
| 4.2.2. | Tuneable Receiver | 32 |
| 4.3. | Related work | 33 |
| 4.4. | System Architecture | 34 |
| 4.5. | 40 GB/S TWDM-PON System Prototype | 41 |
| 4.5.1. | Wavelength Plan for 40 Gbps prototype | 44 |
| 4.5.2. | Simulation Results (40 Gbps TWDM-PON) | 46 |
| 4.6. | 80 GB/S TWDM-PON Prototype | 50 |
| 4.6.1. | Wavelength Plan for 80 Gbps prototype | 54 |
| 4.6.2. | Simulation Results (80 Gbps TWDM-PON) | 56 |
| 5. | Chapter 5: Conclusion and Future Work | 59 |
| 5.1. | Conclusion | 59 |
| 5.2. | Future work | 60 |
| | Appendix | 61 |
| | References | 64 |

DEDICATION

With all love in my heart I dedicate this thesis to:

*My lovely parents, brothers and sisters, for
unlimited and endless love.*

*My lovely wife for Full support at all stages of the
implementation of the thesis.*

My son and daughters.

*To the stars light up our lives, the martyrs and the
wounded and prisoners of freedom.*

Thank you ALL

ACKNOWLEDGMENT

I express my special and deep sense of gratitude to my advisor Dr. Fady El nahal for his invaluable and unlimited support and Constructive advices that inspired me the way to prepare the thesis.

I also acknowledge Dr. Ammar Abo Hadrous , Dr. Talal Skaik, Dr. Anwar Mousa, Dr. Mohammed Housien, Dr. Mohammed Elhanjouri, Dr. Maher Elsofi and Dr. Abdel Hakeim Husein for beneficial advanced subjects and fully supporting me throughout my MSC study.

I acknowledge all Faculty members and administrative staff who have made a lot of effort and giving to overcome the obstacles and provide an ideal environment study.

LIST OF FIGURES

| | |
|---|----|
| Figure 1-1: Active versus Passive Optical Network | 1 |
| Figure 1-2: General structure of a PON | 2 |
| Figure 1-3: Evolution of PON | 3 |
| Figure 1-4: Coexisting GPON and NG-PON1 | 4 |
| Figure 1-5: Global IP Traffic - CISCO VNI Global Forecast 2011-2016 | 7 |
| Figure 1-6: User Data rate evolution | 7 |
| Figure 2-1: Generic structure of a modern telecommunication network | 10 |
| Figure 2-2: operating range of optical fiber | 13 |
| Figure 2-3: Mach-Zehnder modulator | 14 |
| Figure 2-4: AWG structure | 15 |
| Figure 2-5: Point to point access topology | 16 |
| Figure 2-6: Point to Multipoint topology | 17 |
| Figure 3-1: PON architecture | 18 |
| Figure 3-2: OSI Reference Model | 18 |
| Figure 3-3: High-density OLT with 10-GPON & Active Ethernet slots | 19 |
| Figure 3-4: OUTDOOR GPON ONT | 20 |
| Figure 3-5: Schematic drawing for PLC Splitter | 21 |
| Figure 3-6: Optical Access Network Services | 22 |
| Figure 3-7: Typical APON network according to ITU-T G.983 | 24 |
| Figure 3-8: EPON downstream | 26 |
| Figure 3-9: EPON upstream | 26 |
| Figure 3-10: GPON architecture | 27 |
| Figure 3-11: WDM-PON | 28 |
| Figure 3-12: NG-PON roadmap by FSAN | 28 |
| Figure 3-13: ODSM-PON | 29 |
| Figure 3-14 : Schematic diagram of TWDM-PON | 30 |
| Figure 3-15: Stacked XGPON | 30 |
| Figure 4-1: Wavelength management..... | 31 |
| Figure 4-2: TWDM-PON system diagram | 33 |
| Figure 4-3: OLT for 10G-PON..... | 34 |
| Figure 4-4: AWG Mux / DeMux a) 40 Gbps b) 80 Gbps | 35 |
| Figure 4-5: passive Splitter / Combiner | 36 |
| Figure 4-6: ONU Unit | 37 |
| Figure 4-7: Schematic second splitter with 16 ONUs | 39 |
| Figure 4-8: Time Slots for 16 users | 40 |
| Figure 4-9: 40 Gbps TWDM NG-PON2 system architecture | 41 |
| Figure 4-10: 40 Gbps TWDM NG-PON2 system architecture - Optisystem implementation | 42 |
| Figure 4-11: Wavelength Plan options for 40 Gbps | 44 |
| Figure 4-12: downstream wavelengths – spectrum analyzer for 40 Gbps TWDM-PON | 45 |
| Figure 4-13: upstream wavelengths – spectrum analyzer for 40 Gbps TWDM-PON | 46 |
| Figure 4-14: Q Factor for 1555.75 nm downstream at 40 Km | 46 |
| Figure 4-15: Min BER Diagram for 1555.75 downstream nm at 40 Km | 47 |
| Figure 4-16: Eye Diagram for 1555.75 nm downstream at 40 Km | 47 |
| Figure 4-17: Receiver sensitivity for 1555.57 nm | 48 |
| Figure 4 - 18: Receiver sensitivity at 40 Km | 48 |
| Figure 4-19: Q-Factor, Min BER and Eye diagram for 1535.82 nm upstream at 40 Km | 49 |
| Figure 4-20: 80 Gbps TWDM NG-PON2 system architecture | 51 |
| Figure 4-21: 80 Gbps TWDM NG-PON2 system architecture - Optisystem implementation | 52 |

| | |
|--|----|
| Figure 4-22: downstream wavelengths – spectrum analyzer for 40 Gbps TWDM-PON | 54 |
| Figure 4-23: upstream wavelengths – spectrum analyzer for 40 Gbps TWDM-PON..... | 55 |
| Figure 4-24: Q Factor for 1600.6 nm downstream at 40 Km | 56 |
| Figure 4-25: Eye Diagram for 1600.6 nm downstream at 40 Km | 56 |
| Figure 4-26: Receiver sensitivity for 1600.6 nm..... | 57 |
| Figure 4-27: Receiver sensitivity at 40 Km | 58 |

LIST OF TABLES

| | |
|---|----|
| Table 2-1: DSL Technologies bandwidth versus distance capability | 11 |
| Table 2-2: Optical spectral bands | 13 |
| Table 3-1: typical losses for splitters | 21 |
| Table 3-2: PON Technologies | 23 |
| Table 3-3: PON Classes | 23 |
| Table 3-4: BPON Standards | 24 |
| Table 3-5: Wavelength assigned to APON/BPON | 25 |
| Table 3-6: GPON sub-standards | 27 |
| Table 4-1 : Switching Event for 16 users | 38 |
| Table 4-2: system design parameters | 43 |
| Table 4-3: Parameters of 40 Gbps Mux and DeMux | 43 |
| Table 4-4: downstream wavelengths – WDM analyzer for 40 Gbps TWDM-PON | 45 |
| Table 4-5: upstream wavelengths – WDM analyzer for 40 Gbps TWDM-PON | 45 |
| Table 4-6: Parameters of 80 Gbps OLT | 53 |
| Table 4-7: Parameters of 80 Gbps Mux and DeMux | 53 |
| Table 4-8: downstream wavelengths – WDM analyzer for 80 Gbps TWDM-PON | 54 |
| Table 4-9: upstream wavelengths – WDM analyzer for 80 Gbps TWDM-PON | 55 |
| Table 6-1: ITU Grid Standard Wavelengths for Dense WDM Systems | 61 |

Abbreviations, Acronyms, and Terms

| | |
|-----------|--|
| 10G-EPON | 10 Gigabit Ethernet Passive Optical Network |
| 3DTV | Three Dimension TV |
| AON | Active Optical Network |
| APD | Avalanche Photodiodes |
| APON | ATM over Passive Optical Network |
| ATM | Asynchronous Transfer Mode |
| AWG | Arrayed Waveguide Grating |
| B2B | Back-to-Back (0 Km) |
| BER | Bit Error Ratio |
| BPON | Broadband Passive Optical Network |
| BW | Bandwidth |
| CISCO VNI | CISCO Visual Networking Index |
| CO | Central Office |
| CPE | Customer Premises Equipement |
| CW | Continous Wave |
| CWDM | Coarse Wavelength Division Multiplexing |
| DBA | Dynamic Bandwidth Assignment |
| DCF | Dispersion-Compensating Fibres |
| DEMUX | Demultiplexer |
| DFB | Distributed Feedback |
| DS | Down Stream |
| DSL | Digital Subscriber Line |
| DWDM | Dense Wavelength Division Multiplexing |
| EDFA | Erbium-Doped Fibre Amplifier |
| EPON | Ethernet Passive Optical Network |
| FFT | Fast Fourier Transform |
| FP | Fabry-Perot |
| FSAN | Full Service Access Network |
| FTTB | Fibre-to-the-Building |
| FTTC | Fibre-to-the-Curb |
| FTTCab | Fibre-to-the-Cabinet |
| FTTH | Fibre-to-the-Home |
| FTTN | Fibre-to-the-Node |
| FTTx | Fibre-to-the-x |
| FWM | Four-Wave Mixing |
| Gbps | Giga bit per second |
| G-EPON | Gigabit Ethernet Passive Optical Network |
| GPON | Gigabit Passive Optical Network |
| HDTV | High Definition TeleVision |
| HZ | Hertz (Cycle per second) |
| IEEE | Institute of Electrical and Electronics Engineers |
| IPTV | Internet Protocol TV |
| ISDN | Integrated Service Digital Network |
| ISP | Internet Service Provider |
| ITU-T | International Telecommunication Union/ Telecommunication Standardization Sector |
| Laser | Light Amplification by Stimulated Emission of Radiation |
| LED | Light-Emitting Diodes |
| MAC | Media Access Control |

| | |
|----------|--|
| MUX | Multiplexer |
| MZM | Mach-Zehnder Modulator |
| NGA | Next Generation Access |
| NG-PON2 | Next Generation- Passive Optical Network |
| NRZ | Non-Return-to-Zero |
| ODN | Optical Distribution Network |
| ODSM-PON | Opportunistic and dynamic spectrum management PON |
| OFDM | Orthogonal frequency-division multiplexing |
| OLT | Optical Line Terminal |
| ONT | Optical Network Terminal |
| ONU | Optical Network Unit |
| OSA | Optical Spectrum Analyser |
| OSNR | Optical Signal-to-Noise Ratio |
| OTDR | Optical Time Domain Reflectometer |
| P2MP | Point-To-Multi-Point |
| P2P | Point-To-Point |
| PLC | Planar Light Circuit |
| PON | Passive Optical Network |
| POTS | Plain Old Telephone Service |
| QAM | Quadrature amplitude modulation |
| Q-Factor | Quality Factor |
| RZ | Return to Zero (line encoding) |
| SDH | Synchronous Digital Hierarchy |
| SMF | Single Mode Fiber |
| SNR | Signa-to-Noise Ratio |
| SONET | Synchronous Optical Networking |
| TDM | Time Division Multiplexing |
| TDMA | Time Division Multiple Access |
| TDM-PON | Time Division Multiplexing - Passive Optical Network |
| TS | Time Slot |
| TWDM-PON | Time and Wavelength - Passive Optical Network |
| US | Upstream |
| VDSL | Very high speed Digital Subscriber Loop |
| VOD | Vedio-On-Demand |
| VOIP | Voice Over IP |
| WDM | Wavelength Division Multiplexing |
| XG-PON | 10 Gigabit Passive Optical Network |

ABSTRACT

In this research, a design of Passive Optical Network that meets the requirements of Next Generation Passive Optical Network Stage Two (NG-PON2) is. The proposed design was simulated using optisystem software taking into consideration the practical parameters of existing systems. According to The Full Service Access Network (FSAN) – a group of 85 leading telecommunications service providers and telecommunications equipment – The Time and Wave Length Division Multiplexing (TWDM) is chosen on April 2012 as the best solution to implement NG-PON2.

FSAN and International Telecommunication Union/ Telecommunication Standardization Sector (ITU-T) guide the efforts of user needs assessment for bandwidth to plan for smooth network upgrade that meets the user demand with optimal investment and let the user have many options to choose the bandwidth according to his needs within the pay as you grow strategy.

In this thesis a new design objectives like Modular design and 80 Gbps downstream is added ,TWDM network implementation of NG-PON2 with many wavelength plans for both 40 Gbps and 80 Gbps is designed. By the end of the thesis different implementations are compared highlighting the advantages and disadvantages of each.

ملخص الدراسة

يهدف هذا البحث لتصميم شبكة ألياف ضوئية تلبي متطلبات المرحلة الثانية من الجيل القادم من شبكة الألياف الضوئية. حيث سيتم عمل محاكاة للتصميم المقترح باستخدام النسخة الأخيرة من برنامج Optisystem حسب القيم و المتغيرات الحقيقية للأجهزة الموجودة قيد الاستخدام في شركات الاتصالات .

حسب منظمة FSAN و هي عبارة عن مجموعة مكونة من 85 شركة من شركات و مزودي خدمات الاتصالات في العالم ، فان نظام التجميع في مجالي الزمن و الطول الموجي قد تم اختياره في شهر ابريل 2012 كأفضل الحلول المطروحة لتصميم المرحلة الثانية من نظام الجيل القادم لشبكات الاتصالات الضوئية السالبة NG-PON2 .

قادت منظمتنا FSAN و ITU-T الجهود لتحديد احتياجات عرض النطاق لمستخدمي الشبكة و التخطيط المسبق لترقية الشبكات بالمرونة اللازمة التي توفر احتياجات مستخدمي الشبكة مع أقل تكلفة مع توفير خيارات متعددة لعرض النطاق الذي يمكن أن يحصل عليه المشترك بحيث يدفع تكلفة الخدمة التي يتلقاها و يمكن للمشارك الانتقال لسرعة أعلى بمقابل أعلى حسب احتياجات المشترك و رغباته.

في هذا البحث تم تحديد أهداف اضافية لتحقيقها بتصميم نظام مبني علي النمذجة بحيث يمكن مضاعفة وحدات النموذج لمضاعفة عرض النطاق 40 Gbps الي 80 Gbps أو أكثر. كما تم استعراض أكثر من مخطط لمجال الأطوال الموجية المستخدمة و مقارنة النتائج لتوضيح مزايا و عيوب كل من هذه المخططات.

Chapter 1: Introduction

1.1.Introduction

The great growth in user demand for bandwidth due to today's network applications stir the competition between network carriers to meet the user demands. FSAN began studies to assess needs in late 2010, they concluded that there is a great gap between user needs and the bandwidth offered by the 10 Gbps capable Passive Optical Network (10G-PON known as XG-PON) technologies. A system proposal for Next Generation- Passive Optical Network (NG-PON) stage 2 was commenced in 2011. Among other solutions Time and Wavelength - Passive Optical Network (TWDM-PON) technology was recommended at the April 2012 meeting as a primary solution to design and implement NG-PON2 [1]. The network design achieves main design objectives like available bandwidth, network reach and cost [2].

In this thesis a modular design of TWDM-PON net is implemented and tested against wavelength assignment plans and reliability of network design is verified.

1.2.Background

Unlike Active Optical Network (AON) [3 , 4] which uses an active devices and network elements to connect operator to end user, A PON is Green Technology that uses passive optical splitter to connect to end user device.

The main difference between AON and PON is that AON uses electrically powered network devices in the optical distribution network (ODN) while Passive optical network as its name implies uses passive components (passive power splitter) in the distribution network to connect the user to the operator network (see Figure 1-1) this means electrically powered components are available only at Central Office (CO) side Optical Line Terminal (OLT) and user side Optical Network Unit (ONU).

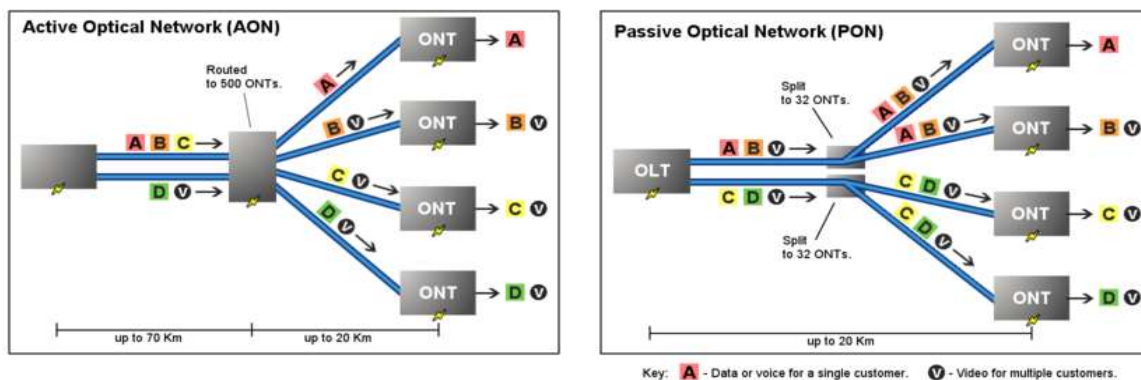

Figure 1-1: Active versus Passive Optical Network [5]

Some applications of passive optical network referred as fiber to x (FTTx) according to how close the fiber cable to the end user (see figure 1-2) that describes the general structure of a PON. Many applications of FTTx can be implemented like Fiber to the Home (FTTH), Fiber to the cabinet (FTTC), Fiber to the Node (FTTN) or Fiber to the Building (FTTB).

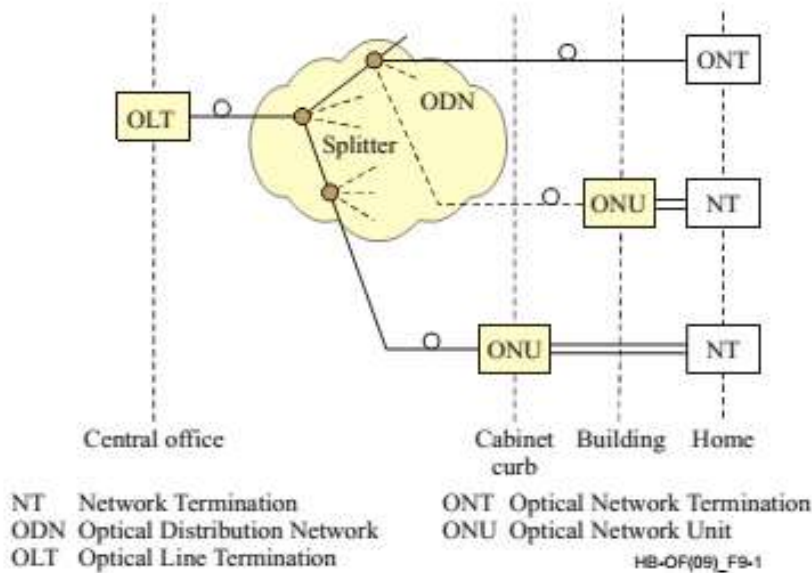

Figure 1-2: General structure of a PON [6]

1.3.NG-PON

Passive Optical Networks evolution passed many steps toward NG-PON2. The previous technologies of PONs was developed to meet user requirements of bandwidth .There are different PON technologies from FSAN, ITU-T and parallel efforts by IEEE [7]. There are many implementations of PON technology, like Asynchronous Transfer Mode (ATM) over Passive Optical Network (APON) standardized as G.983.1and G.983.2 at the year 1995 with 155 Mbps upstream and 155 Mbps downstream , Broadband Passive Optical Network (BPON) with standards G.983.3 to G.983.5 at the year 2000 raising the data rates to 625 Mbps downstream, Gigabit Passive Optical Network (GPON) with 2.5 Gbps downstream and 1.25 Gbps upstream standardized at the year 2001 as G.984.1 to G.984.4 and new ammendments added at the year 2006, Ethernet Passive Optical Network (EPON) is standardized by IEEE at the year 2001 as IEEE 802.3ah to support symmetric 1Gbps upstream and downstream, Gigabit Ethernet Passive Optical Network (G-EPON) , 10 Gigabit Ethernet Passive Optical Network (10G-EPON) increased the upstream and downstream data rates to 10 Gbps and standardized as IEEE 802.3av at the year 2007 ,NG-PON1 and NG-PON2 (see figure 1-3).

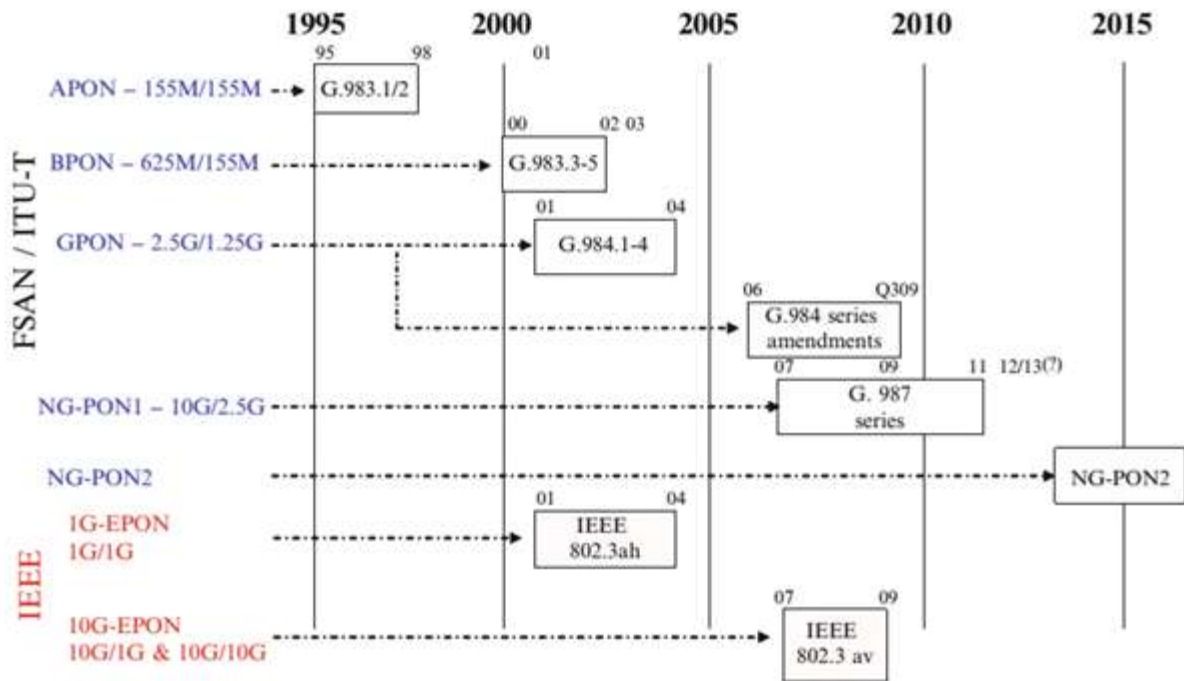

Figure 1-3: Evolution of PON

1.3.1. NG-PON1

NG-PON1 is the first stage of next generation standards by FSAN/ITU-T started at 2007 as standard G.987.x series with 10 Gbps downstream and 2.5 Gbps upstream data rate.

The main task NG-PON1 [46] was to build a PON that coexist with existing optical doplyments (see figure 1-4) and have backword compatability with legacy GPON deployment [8].

XG-PON1 was implemented to provide per user data rates 10Gbps DS and 2.5 Gbps US.

XG-PON2 was implemented to provide per user data symmetrical rates 10Gbps DS and US.

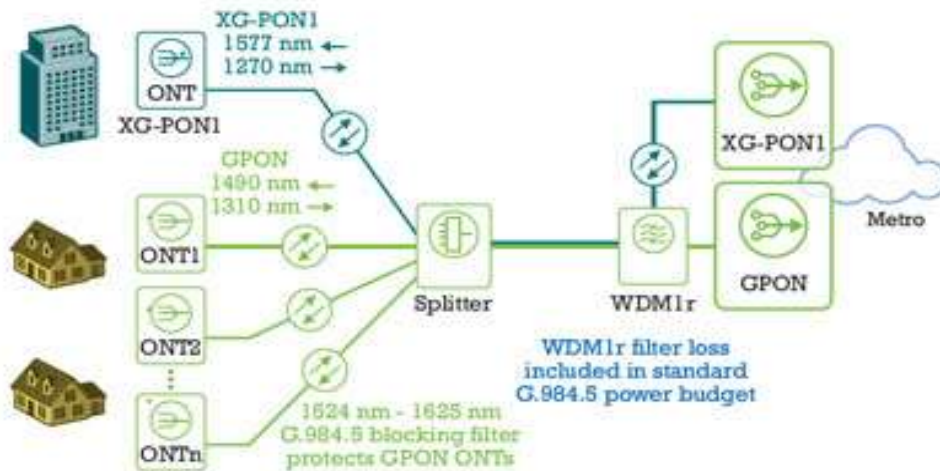

Figure 1-4: Coexisting GPON and NG-PON1

1.3.2. NG-PON2

The new approach, NG-PON2, will increase PON capacity to at least 40 Gbps and deliver services of 1 Gbps or more with platforms and standards that could be deployable in 2015 (see figure 1-3). It is designed to meet a broad range of communications needs, including business and mobile backhaul applications as well as residential access. This means that NG-PON2 can support increased capacity, higher light-to-port ratios, improved interoperability and enhanced services [9].

After the completion of XG-PON1 project, FSAN and ITU-T started in the late 2010 to work on NG-PON2 by requirements assessment then in 2011 they studied the available proposals for implementations. Four proposals were under study:

- 1- TDM-PON : this proposal is to increase the downstream bit rate of the previously defined XG-PON1 from 10 Gbps to 40 Gbps. This solution requires very high data rate electronics that is not available yet. With the need more investment in new network devices.
- 2- WDM-PON : this approach provides a dedicated wavelength channel for each user with data rate 1 Gbps. The wavelength spectrum available should be used with high efficiency so ultra-dense WDM should be used to serve large number of users, The main problem of this approach is high cost of transmitters with precise laser output wavelength and receivers with precise filters.
- 3- Digital OFDM-PON : it employs three types of OFDM-PONs each one applies QAM and FFT to generate digital OFDM signals.

- 4- TWDM-PON: in this approach four pairs of wavelengths is used to support aggregate 40Gbps downstream and 10 Gbps upstream data rate. This approach is chosen as the primary solution

1.4.Literature Review

TWDM-PON system is designed, implemented and tested against many wavelength plans. The first wavelength plan reuse the XG-PON wavelengths and hence TWDM-PON cannot coexist with XG-PON. The second plan uses C-Band (shown ITU Grid Standard Wavelengths for Dense WDM Systems - appendix A), this plan enables coexistence between TWDM-PON and previous PON technologies including XG-PON, so the telecom company can offer smooth upgrade with pay as you grow strategy.

The TWDM-PON OLT consists of 4 or 8 10G-PON transceivers each one utilizes pair of wavelengths, the transceivers are multiplexed using Arrayed Waveguide Grating (AWG) as multiplexer/de-multiplexer, then the multiplexed data signal is amplified and sent over 40 Km single mode optical fiber to the user Optical Network Unit (ONU) via the Optical Distribution Network (ODN) which consists of two stages of passive power splitters.

The design is modular so that it can be upgraded to more than 8 transceivers choosing the appropriate wavelength plan taking into consideration the option of replace or co-exist with previous technologies.

1.5.Research Problem

Today's communication network traffic is converged voice, video and data network. According to the developed applications and services previously described, user demand increases every year making it vital for telecommunication companies and carriers to increase their network capacity as a primary and most important characteristic of broadband access network.

High Bandwidth demand applications for home user and business applications [10].

- Peer-to-peer file transfer like emule, bittorrent, LimeWire and shareaza
- Video file transfer and Video on demand (VOD) like YouTube, Daily Motion
- Internet protocol TV (IPTV) applications with different resolutions such as Standard definition TV (SDTV) with 720x576 pixels per frame, High Definition TV (HDTV) with 1280x720 pixels, Full HD with 1920x1080 pixels Ultrahigh Definition TV (UHDTV) known as 4k technology with 4096x2160 pixels, the upcoming 8k standard and Three Dimension TV (3DTV)
- Voice over IP (VOIP) like Skype and OOVOO

- Video conference like OOVVOO
- Online Games
- Cloud computing like Office 365 and Google documents
- Online storage like OneDrive, UpToBox and mediafire
- Remote backup
- Interactive Learning used for online learning like CISCO academy programs and many others
- Telemedicine Services

1.6.Motivation and Objectives

The main research objective is to design a high performance optical access network according to (NG-PON2) recommendations.

1. The aggregate Downstream bitrate is at least 40 Gbps upto 100 Gbps.
2. The aggregate Upstream is 10 Gbps up to 40 Gbps.
3. The reach distance from central office OLT to the user ONU is 40 Km.
4. The splitt ratio is Up to 1:64 so that maximum number of users can share the same fiber to reduce the number of fibers serving any area and hence reduce the cost per user .
5. Acording to FSAN TWDM-PON system is recommended.
6. Modular design that can be repeated with more interfaces at ISP.
7. Co-exist with previous PON systems (optional for smooth upgrade).

A system model is built and tested using Optisystem 13

Network companies can measure user requirements by counting the traffic passing through network nodes and using statistical data analysis they can predict the future traffic requirements which is vital for planning network upgrades smoothly to meet the everyday increase in traffic through the network.

CISCO Visual Networking Index (VNI) Global Forecast (2011-2016) (see figure 1-5) from which network operators can predict four-fold increase in Global IP traffic (Exa equals 10^{18}).

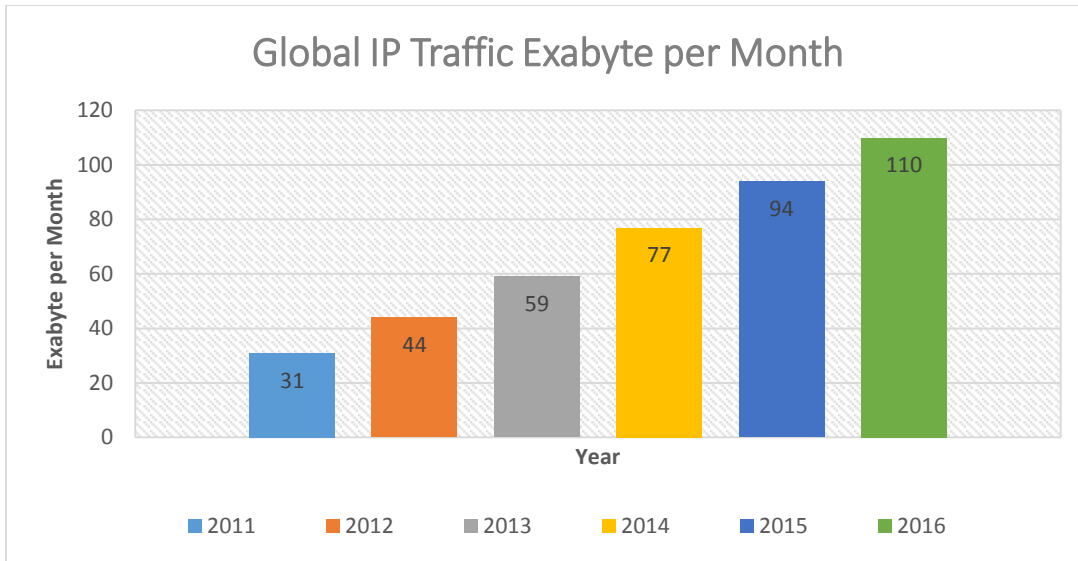

Figure 1-5: Global IP Traffic - CISCO VNI Global Forecast 2011-2016 [11]

This urges the telecommunications companies to upgrade their networks according to meet the future needs for users.

The data rates passed many progress steps (see figure 1-6) from the first days of copper cables to future expectation for mobile and fixed broadband FTTH utilizing fiber cables. Telecommunication networks passed many upgrades from the first generation with very low data rates for sending text between remote network units to future prediction of data rate required for single user.

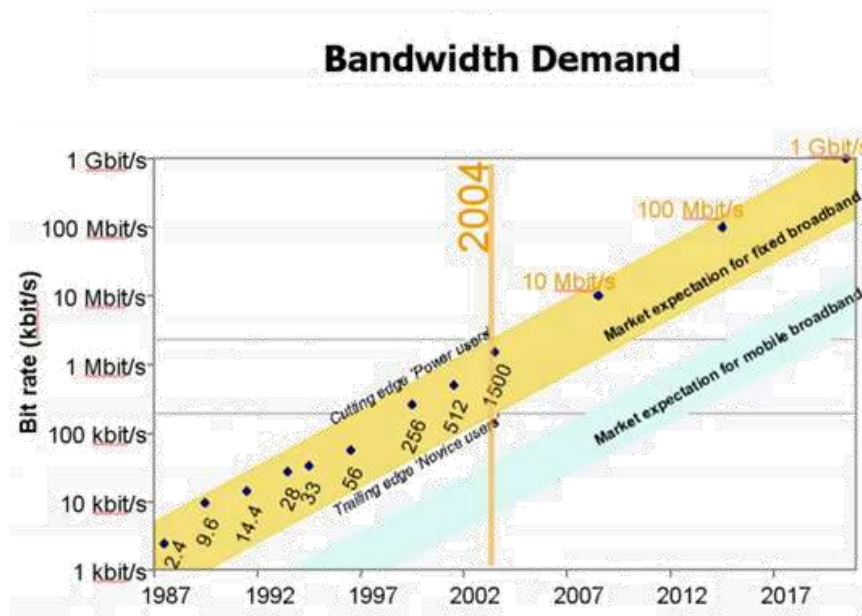

Figure 1-6: User Data rate evolution [12]

1.7. Methodology & Implementation

Since optical network devices are very expensive, network designers cannot test network design with real network devices as they can change the design many times to enhance and optimize the network. Computer aided design tools are common to be used in network design to test and optimize before implementing the design in the real-world [13].

Optisystem is an innovative, rapidly evolving and powerful optical network design tool that enables user to plan, test, optimize and simulate optical communication systems from components to system level. User can change component parameters and connections to test endless scenarios in minimum time and decrease cost of design with high precision simulation of nonlinear devices and non-Gaussian noise sources with results to industry.

Optisystem can be used for design variety of applications such as PON, WDM/TDM, Synchronous Optical Networking / Synchronous Digital Hierarchy (SONET/SDH), link budget calculations and transmitter, channel, amplifier receiver design.

Optisystem offers some useful tools such as parameter sweep and optimization. Parameter sweep lets the user input range of values for one component parameter or more to test the output against that range and specify output peaks and vales related to that input. Nested sweep enables designer to perform multidimensional analysis to get better values. While optimization is used to set any component parameter to value required to maximize, minimize or set output to target value.

Key features of Optisystem

- Comprehensive graphical user interface
- Extensive component library
- User-defined components
- Integration with other Optiwave tools
- Mixed signal representation
- Parameters sweep and optimization
- Quality and performance algorithms
- Advanced visualization tools
- Data monitors
- State-of-the-art calculation data flow
- Powerful script language
- Report page
- Bill of materials
- Multiple layouts

Optisystem replicates the real system, so the results of the design simulation is applicable and can be implemented in the real-world network.

1.8. Novelty aspects

The NG-PON2 is a project guided by FSAN initiated at April 2012 with time period of project extends to 2020. The main goals of project are defined according to vision of FSAN but the researchers compete to add their designs to the project. So there are many designs can be implemented. The novelty aspects in this research are:

1. Data Rate increased to 80 Gbps (started at 40 Gbps then increased the rate with design tradeoff between data rate and cost of implementation to maximum number of users)
2. The number of users sharing the same fiber link increased to 128.

1.9. Outlines of Thesis

This work deals with the new method of NG-PON2. In the previous section, the background of NG-PON2 was discussed an introduction to the thesis defining the problem and the objectives met by the end of this thesis. Short introduction to Optisystem software tool used for optical network design with scope and applications of that software.

Chapter two introduces to the field of optical Access Networks and the user needs and capacity formula that describe the pathway to fiber access network is explained.

Chapter three describes PONs highlighting the advantages of PONs, then different implementations of PONs explained with details of network design, network elements, wavelength plan and other parameters of each technology. Possible solutions to implement NG-PON2 is explained with more details highlighting the different methods of implementation.

Chapter four shows different TWDM implementation for NG-PON2 with details of key technologies as ONU tunable transmitter and receiver, TWDM NG-PON2 system design is implemented and tested for 40 Gbps data rate then a higher version with data rate of 80 Gbps is examined.

Chapter five summarizes the NG-PON2 technology and TWDM implementation and future work vision is described.

Chapter 2: Broadband Access Networks

2.1. Introduction

Telecommunications network consists mainly of three segments backbone/core/long-haul network, metro/regional network and access network. In the Plain Old Telephone System (POTS) with only voice services utilized mainly two types of transmission media

- 1- Twisted pairs of copper wires to carry analog voice signals and low data rate user data to central office.
- 2- Optical fibers in the long haul trunk links between central offices to carry multiplexed subscriber voice signals.

The last years noticed a great development in the telecommunications network introducing the optical fiber into the access segment of the network.

Various implementations of Access networks (see Figure 2-1) [14].

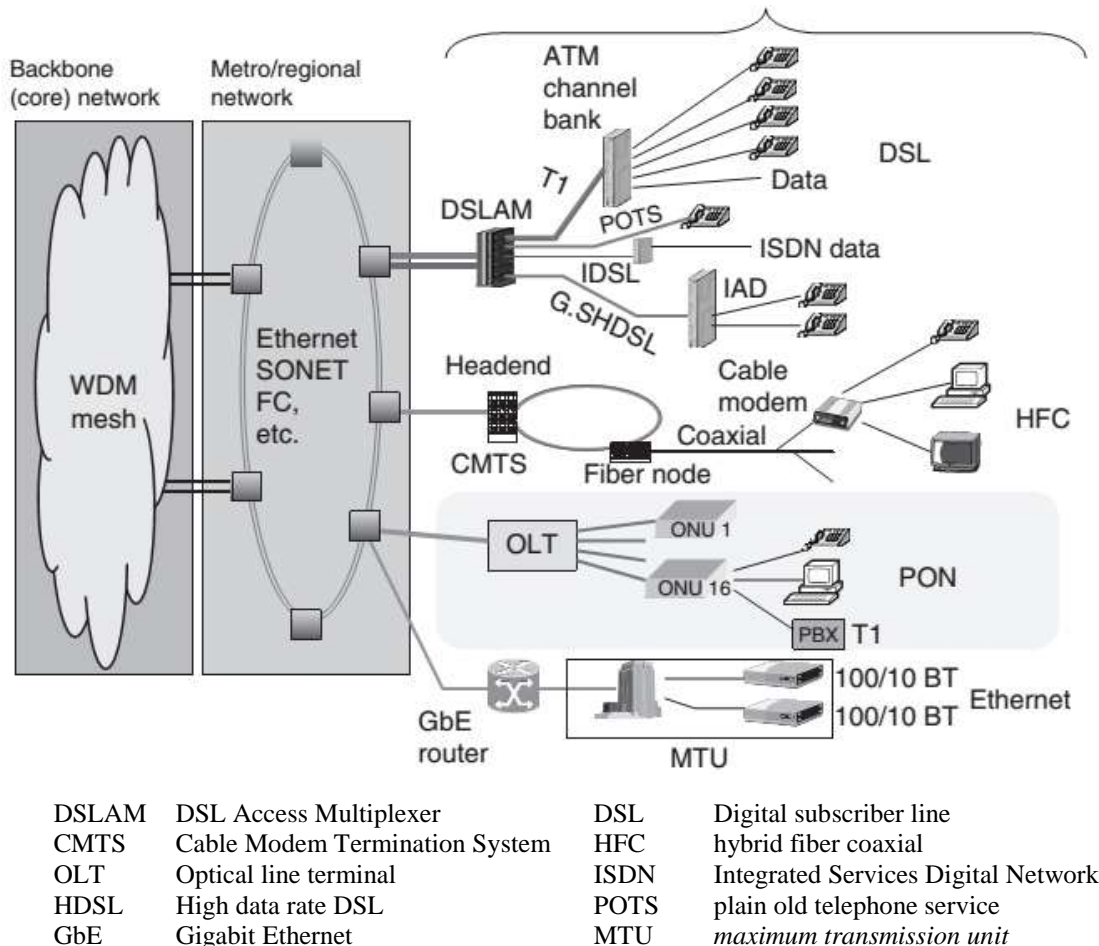

Figure 2-1: Generic structure of a modern telecommunication network [48]

2.2. The need for optical fiber in broadband access network segment.

A broadband access network offers various high-speed services to the end user such as internet, multimedia, telemedicine and distant learning.

The history of broadband access network points to copper wires (twisted-pair cables) made the local loop from telecommunication operator central office to the user device.

Copper media access technologies like Digital Subscriber Line (DSL) or cable-modem access suffers bottleneck in bandwidth-on-demand performance as they limit the bit rate to a maximum value that does not satisfy today and future user requirements. This limit is described by the Shannon-Hartly theorem [15].

$$C = BW \times \log_2(1 + SNR) \quad (2-1)$$

Where C refers to capacity measured bits per second (bps) , BW is Bandwidth measured in Hz and SNR is the Signal to Noise Ratio of the channel on the receiver.

Table 2-1 reviews some of DSL access technologies that uses copper wires to connect the user CPE. The table also shows the maximum upstream and downstream data rates for minimum length and minimum SNR. Increasing the cable length results in increasing SNR and hence decreases the data rate [16].

Table 2-1: DSL Technologies bandwidth versus distance capability

| Technology | Max Upstream Capacity | Max Downstream Capacity | Max Distance | Downstream Capacity @ Max Distance | Frequency Range |
|------------|-----------------------|-------------------------|--------------|------------------------------------|-----------------|
| ADSL | 640 Kbps | 12 Mbps (0.3km) | 5.4 km | 1.5 Mbps | Up to 1.1 MHz |
| SDSL | 3 Mbps | 3 Mbps | 2.7 km | 2 Mbps | Up to 1.1 MHz |
| ADSL 2+ | 1 Mbps | 26 Mbps (0.3km) | 3.6 km | 4 Mbps | Up to 2.2 MHz |
| VDSL | 16 Mbps | 52 Mbps (0.3km) | 1.3 km | 13 Mbps | Up to 12 MHz |

Table 2-1 shows various xDSL technologies with maximum theoretical downstream and upstream data rates and maximum distance with practical downstream and upstream rates at maximum distance. It is obvious that the maximum distance is limited to 5.4 km and the maximum downstream data rate is severely decreased due to low SNR caused by distance.

Shannon theory traced the base line for data communication system capacity limits over noisy channel of old telephone line cables. This problem arises the need for communications over optical fiber.

the optical fibers was used only for core network connections between central offices for the demand of high traffic. These days and in the future with the growth of competition between

telecommunication companies to offer advanced services that needs very high data rates – at least 50 Mbps Downstream and 10 Mbps Upstream per user at peak time - the service providers offer optical access networks. The telecommunication business seeking the highest capacity with the lowest cost [17].

It is found that the access network consists of active devices in the distribution network that need electric power and backup batteries in case of power failure. The solution for those problems leads to green network technologies with no power requirements in the distribution network highlighted as passive optical network (PON) which will be studied thoroughly in chapter 3.

2.3.Advantages of fiber optical cables:

- 1- Future proof: optical fiber has a high bandwidth spectrum as shown in figure 2-2 and table 2-2, this allows unlimited internet speeds in the future [18].
- 2- Low resistance: this characteristic has a great importance enabling the optical signal to be sent over very long distances with no need for amplification. Figure 4 shows the attenuation versus wavelength for a single mode fiber, it is clear that the fiber cable has three low attenuation windows at 850 nm, 1310 nm and 1550 nm (see figure 2-2), and these windows are preferable for transmission over long distances. with minimum fiber attenuation where most optical networks device vendors and optical network designers specify upstream and downstream optical signals. [19].
- 3- Immunity to electromagnetic interference: in contrast with copper wires, fiber cables do not suffer from electromagnetic interference so optical signals can be sent reliably for long distances with acceptable bit error rate BER.
- 4- Data security, where it is no radiation of signals outside the core of the fiber cable so no one can sniff the optical light signals without interrupting the cable and it is easy to detect any interruption trial.
- 5- The optical fiber cable is easy to install where there are dedicated ships to lay the cables in the seas and oceans, there is also special vehicles to open slots beside or under the roads, others to lay the cable in the slots and close the slots again leaving manholes for cable test and repair. Moreover fiber cables termination tools are available and easy to use for cable connection.

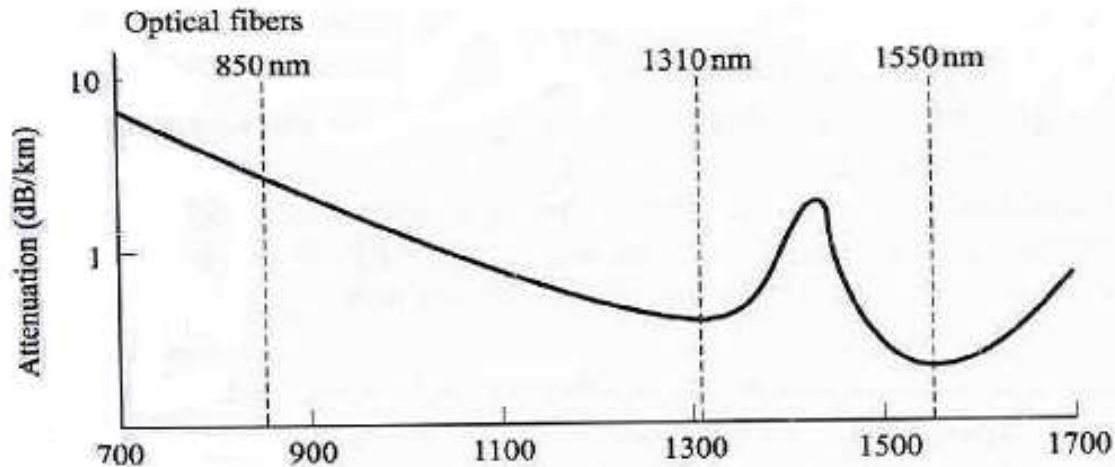

Figure 2-2: operating range of optical fiber

2.4. Optical cable wavelength Spectrum

The usable wavelength spectrum for optical fiber cables extends from 1260 nm to 1675 nm. The wavelength spectrum is divided to six main bands as shown in table [20].

Table 2-2: Optical spectral bands

| Band | Description | Wavelength (nm) |
|--------|-----------------------|-------------------|
| O-Band | Original | 1260 – 1360 |
| E-Band | Extended | 1360 – 1460 |
| S-Band | Short wavelength | 1460 – 1530 |
| C-Band | Conventional | 1530 – 1565 |
| L-Band | Long wavelength | 1565 – 1625 |
| U-Band | Ultra-Long wavelength | 1625 – 1675 |

For Standard wavelength carriers that are used in Dense Wave Length Division Multiplexing (DWDM) systems as specified by ITU for C-band and L-Band (see Appendix A) [21].

2.5. Optical Network Devices

Optical networks consists mainly of optical transmitter, optical distribution network and optical receiver.

Optical transmitter sends data as optical signal to be transmitted over fiber cables, the electric data modulates the laser directly or using external modulator like Mach-Zehnder modulator. Optical transmitter can multiplex more than on light signal that are loaded to different wavelength carriers using Wavelength Division Multiplexer (WDM).

The optical distribution network consists mainly of fiber and branching device. The fiber cable can be single mode fiber or multimode fiber, the type of cable is decided according to attenuation, dispersion and other characteristics. The branching device can be simply power splitter or power and wavelength splitter.

The optical receiver receives and selects optical signal then converts it to electric signal to extract the data. Some optical devices used in the TWDM-PON network in this thesis are explained in the next sections.

2.5.1. Mach-Zehnder Modulator

The Mach-Zehnder modulator is an intensity modulator based on an interferometry principle. It consists of two 3 dB couplers which are connected by two waveguides of equal length (see in figure 2-3). By means of an electro-optic effect, an externally applied voltage can be used to vary the refractive indices in the waveguide branches.

The different paths can lead to constructive and destructive interference at the output, depending on the applied voltage. Then the output intensity can be modulated according to the voltage [22].

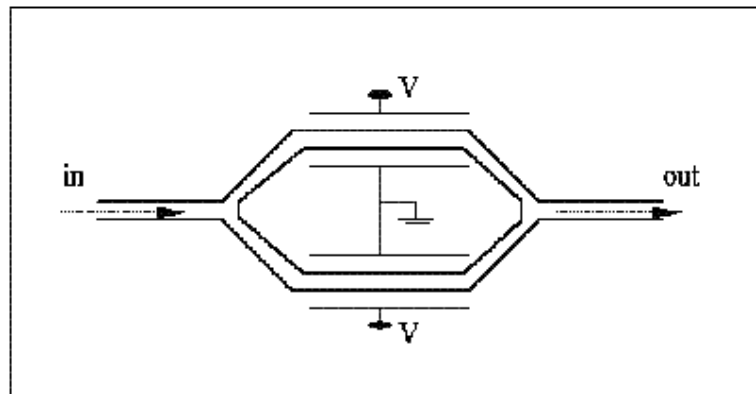

Figure 2-3: Mach-Zehnder modulator [24]

2.5.2. Arrayed Waveguide Grating (AWG)

AWG is a planar structure of waveguides that consists of an array of waveguides called phased array and free propagation region contains two couplers (see figure 2-4). Optical signal of multiple wavelengths $\lambda_1 - \lambda_n$ flows from one of the input waveguides into the input coupler which distributes the light signal amongst an array of waveguides of different lengths.

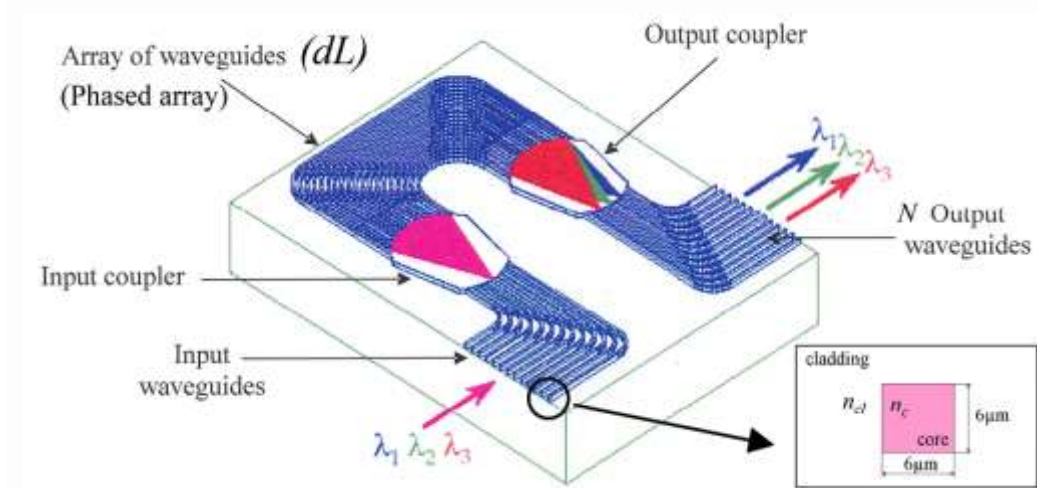

Figure 2-4: AWG structure [25]

Then the light signal propagates through the array of waveguides to the output coupler. The lengths of waveguides of the array are designed so that the path difference dL between adjacent waveguides equals an integer multiple of the central wavelength λ_c of the demultiplexer.

The path length difference between adjacent array arms dL is given by (equation 2-2)

$$dL = \frac{m \lambda_c}{n_{eff}} \quad (2-2)$$

Where n is the number of waveguides, m refers to diffraction order of the demultiplexer, n_{eff} is the effective refractive index of the arrayed waveguides and λ_c is the center wavelength of the phasar.

For this wavelength the fields in the individual arrayed waveguides will arrive at the input of the output coupler with equal phase, and the field distribution at the output of the input coupler will be reproduced at the input of the output coupler.

by increasing length of the array waveguides linearly causes interference and diffraction when light mixes in the output coupler. As a result, each wavelength is focused into only one of the N output waveguides called output channels.

AWGs can be divided into low-index and high-index AWGs. Low-index AWGs with a refractive index contrast of 0.75% this type is compatible with optical fibers and has low coupling losses between output waveguides and optical fibers. It has size disadvantages when number of channels increases. High index AWGs have the advantages of small size and higher coupling losses.

AWG devices serve as multiplexers, demultiplexers, filters, and add-drop devices in optical WDM and DWDM applications [23].

2.6. Optical Access network topologies

Optical access networks either active optical networks (AONs) or passive optical networks (PONs) offers increasing data rate to the end user to support the everyday increase in bandwidth demand for today and future applications.

Optical access networks can be connected in two main topologies point-to-point (P2P) or point to multi-point (P2MP) [24].

2.6.1. Point-to-point configuration (P2P)

P2P is a direct dedicated link between central office (CO) and user equipment (UE) (see figure 2-5). The user is mainly companies or business offices requiring huge data transfer with remote sites. In P2P topology the bandwidth is dedicated to user with very high cost [25].

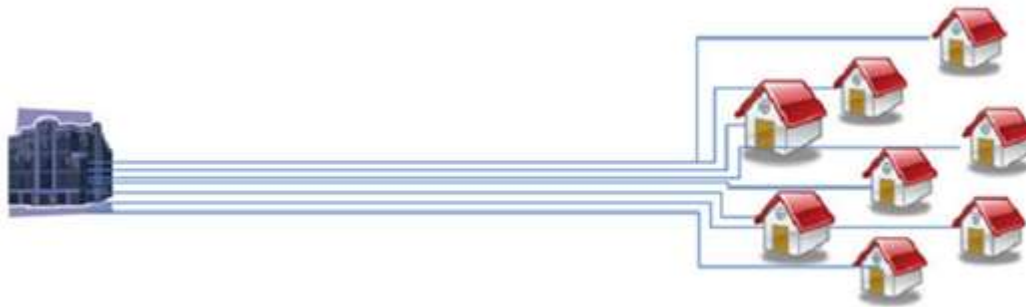

Figure 2-5: Point to point access topology [27]

2.6.2. Point-to-multipoint configuration (P2MP)

Any network user does not use the network resources in the same manner (i.e. there will be peaks and valleys) the high speed link from CO can be shared between groups of users. This topology is suitable for home users and small offices [16].

The shared fiber can carry TDM data or WDM data or hybrid directed to multiple users.



Figure 2-6: Point to Multipoint topology [27]

Point-to-multipoint cost of implementation and operation less than Point-to-point because the shared portion cost will be shared between all the users served by the same fiber.

Chapter 3: Passive Optical Networks

3.1.Introduction

PON consists mainly of an optical Line Terminal (OLT), several Optical Network Terminal (ONT) or Optical Network Units (ONUs) and Optical Distribution Network (ODN) that connects OLT and ONUs (see figure 3-1) [26].

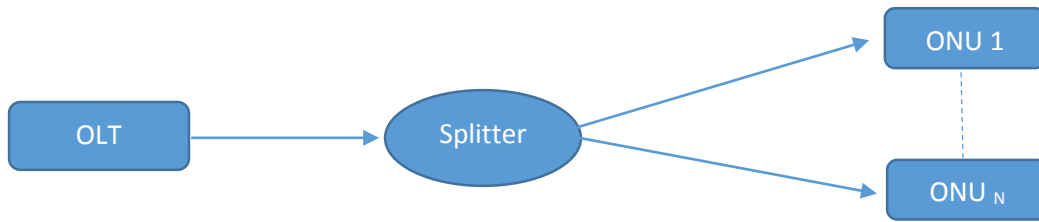

Figure 3-1: PON architecture [28]

The difference between ONT and ONU is presented briefly as ONU is a device that terminates distributed endpoints of ODN and ONT is subscriber device that terminates distributed endpoints of ODN and it is considered a special form of ONU (refer to figure 1-2).

3.1.1. Optical Line Terminal (OLT)

OLT is the CO side device interfaces the backbone network to access network. OLT consists of media access control (MAC) layer protocol, optical transmitter and optical receiver [27].

MAC Layer (see figure 3-2) is the second layer of the open system interconnect protocol (OSI) model defines how data can be sent to or received from user and how wavelengths or time slots will be assigned to different user devices.

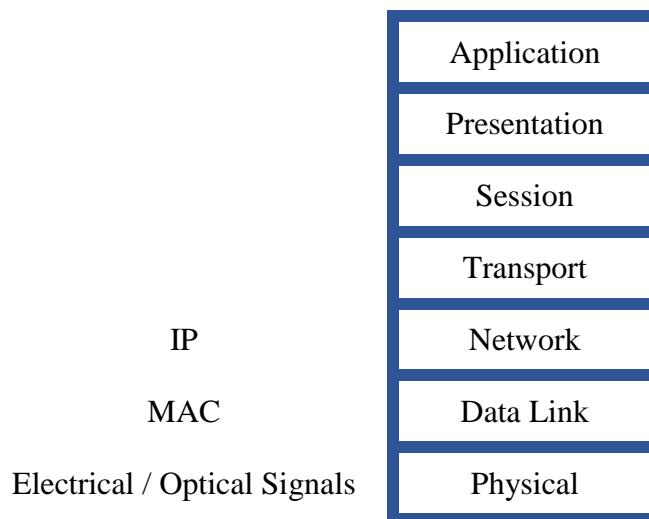

Figure 3-2: OSI Reference Model

Optical transmitter encodes user data signals using one of the line coding schemes (i.e. return to zero (RZ), non-return to zero (NRZ), Manchester ...) then modulates the encoded signal using optical source with wavelength and power required for transmission.

Optical receiver get and separate the user data from the ODN, then demodulate and decode the user data and direct it to the back-haul network.

OLT controls data flow across the ODN into two directions with different wavelength for each to avoid interference between the contents of downlink and uplink channel

In downstream direction, the OLT multiplex voice, data and video traffic using TDM, WDM or both and launch the multiplexed optical signal over the ODN to the user ONUs.

In the upstream direction, the OLT receives all user traffic coming from ONUs across ODN and direct it to the backbone network (see figure 3-3).



Figure 3-3: High-density OLT with 10-GPON & Active Ethernet slots [28]

OLT can support a variety of services on the same fiber with different wavelength for each service, for example for PON The 1490 nm wavelength for downstream voice and data traffic, the 1550 nm wavelength for video distribution and 1310 nm wavelength for upstream voice and data traffic [29].

3.1.2. Optical Network Terminal ONT

ONT is the user side device that interfaces optically to optical access network PON at one side and electrically to user's equipment at user side [30]. ONT are available in many form factors for many services like GPON ONT (see figure 3-4). it can aggregate, groom, and transport various types of information traffic from the user and send it over a single-fiber PON infrastructure to OLT [31].



Figure 3-4: OUTDOOR GPON ONT [32]

3.1.3. Optical Splitter

Splitter is the main element in PON since it is passive power divider that gives Passive Optical Network its name. It is known as splitter but it is bidirectional device that divide the power downstream optical signal from OLT to all splitter outputs connected to ONTs, it also combines the incoming upstream signals from ONTs to one fiber connecting to OLT.

The losses due to power division limits the number of outputs N connecting to ONTs or split ratio [33].

$$Attenuation_{splitter} = 10 \log \frac{1}{N} \quad (3-1)$$

There are mainly two types of splitters

- Splitters based on planar technology for split ratio > 32
- Splitters based on fused bi-conical couplers for split ratio < 32

Figure 3-5 shows the schematic [34] of PLC splitter while table 3-1 lists typical losses due to split ratio.

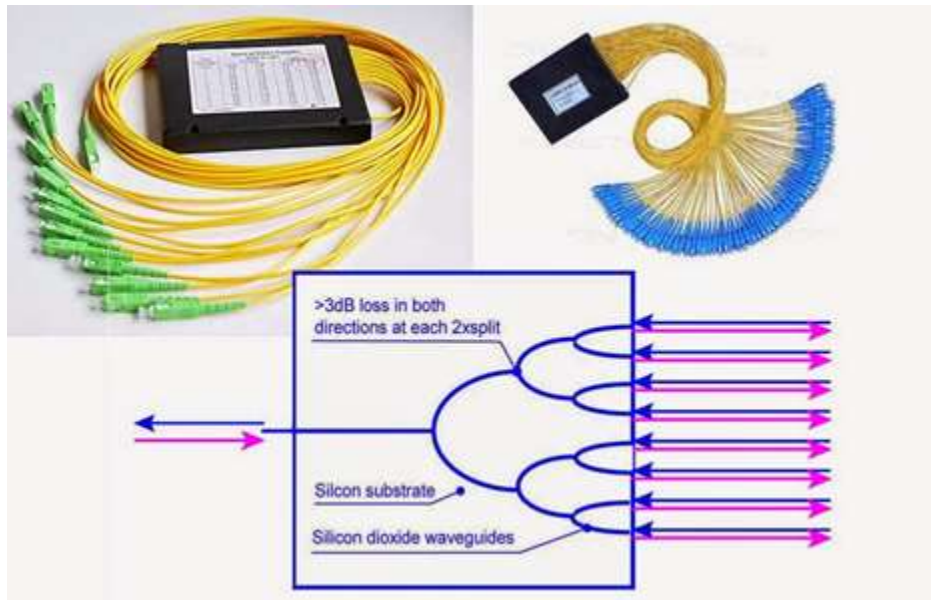

Figure 3-5: Schematic drawing for PLC Splitter [35]

Table 3-1: typical losses for splitters [36]

| Splitter Ratio | 1:2 | 1:4 | 1:8 | 1:16 | 1:32 |
|------------------------|-----|-----|-----|------|------|
| Ideal Loss / Port (dB) | 3 | 6 | 9 | 12 | 15 |
| Excess Loss (dB, max) | 1 | 1 | 2 | 3 | 4 |
| Typical Loss (dB) | 4 | 7 | 11 | 15 | 19 |

3.2. Advantages of PON

The Advantages of PON is given by the following;

1. Cost effective implementation due to shared optical link and no need for backup batteries and un-interrubtable power supply.
2. Very low energy consumption due to passive components and low attenuation of fiber cables (Greaan Technology).
3. Longer distance between CO and customers sharing the same trunk. This is result of the very low attenuation of fiber cable (see fig 3-6).

4. More signals in one fiber to cabinet allows for very dense CO equipment.
5. Much higher bandwidth per user.
6. As point to multi point allows for downstream video broadcasting.
7. No need for multiplexing or demultiplexing components in cabinets [37].

According to how close the fiber to the user, the P2MP is classified as [38].

FTTC (Fiber to the Curb): the shared optical fiber cable run from CO to distribution device located within 300 m from the home or the building (Curb), then a dedicated cable (twisted-pair) is connected from the curbside to the device in the customer building.

FTTB (Fiber to the Building): the optical fiber is reaching the building of the business or enterprise.

FTTN (Fiber to the Node): the shared optical fiber cable run from CO to distribution device located within 1000 m from the home or the building (Curb).

FTTH (Fiber to the Home): the optical fiber cable run from central office to the home.

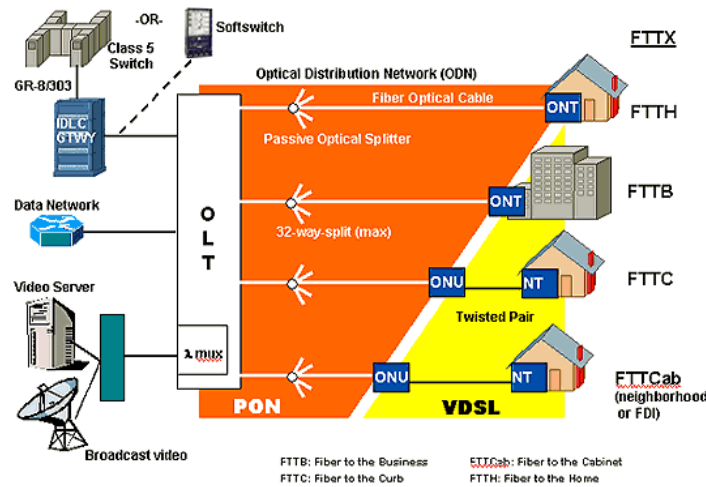

Figure 3-6: Optical Access Network Services [39]

3.3. PON standards

FSAN and ITU-T lunched many meetings and confrences to assess needs for data rates, define the problem, discuss possible solutions and make recommendations for researchers to start design and test their own solutions.

Table 3-2 lists PON technologies with comparison of data packet size , maximum and minimum upstream and downstream data rates split ratio and distance.

Table 3-2: PON Technologies [40]

| technology | A/BPON | EPON (GEPON) | GPON | 10 GEPON | WDM PON |
|------------------------------|------------------|--------------------|---------------------|---|-------------------------------|
| Standard | ITU G.983 | IEEE802ah | ITU G.984 | IEEE P802.3av | ITU G.983 |
| Data Packet Cell Size | 53 bytes | 1518 bytes | 53 to 1518 bytes | 1518 bytes | Independent |
| Maximum Downstream Line Rate | 622 Mbps | 1.2 Gbps | 2.4 Gbps | IP; 2.4 Gbps, Broadcast; 5 Gbps On-demand; 2.5 Gbps | 1-10 Gbit/s per channel |
| Maximum Upstream Line Rate | 155/622 Mbps | 1.2 Gbps | 1.2 Gbps | 2.5 Gbps | 1-10 Gbit/s per channel |
| Downstream wavelength | 1490 and 1550 nm | 1550 nm | 1490 and 1550 nm | 1550 nm | Individual wavelength/channel |
| Upstream wavelength | 1310 nm | 1310 nm | 1310 nm | 1310 nm | Individual wavelength/channel |
| Traffic Modes | ATM | Ethernet | ATM Ethernet or TDM | Ethernet | Protocol Independent |
| Voice | ATM | VoIP | TDM | VoIP | Independent |
| Video | 1550 nm overlay | 1550 nm overlay/IP | 1550 nm overlay/IP | IP | 1550 nm overlay/ IP |
| Max PON Splits | 32 | 32 | 64 | 32 | 16 to 100 and more |
| Max Distance | 20 Km | 20 Km | 60 Km | 10 Km | 20 Km |
| Average Bandwidth per User | 20 Mbit/s | 60 Mbit/s | 40 Mbit/s | 20 Mbit/s | Up to 10 Gbit/s |

Passive optical networks are classified to three classes defining minimum loss, maximum loss and maximum number of ONUs as shown in the table 3-3.

Table 3-3: PON Classes [42]

| | Class A (622 Mbps only) | Class B | Class C |
|---------------|-------------------------|----------|----------|
| Min. loss | 5 dB | 10 dB | 15 dB |
| Max. loss | 20 dB | 25 dB | 30 dB |
| ONUs Max. No. | Up to 8 | Up to 16 | Up to 32 |

3.3.1. APON / BPON

Seven telecommunications operators initiated PON multiservice broadband access for business customers adopted by FSAN/ITU-T in 1995 by merging ATM service and PON and they called it APON and it was first PON technology for FTTx applications. later in 1996 they changed the name to BPON. Figure 3-8 describes the structure of typical APON network according to ITU-T G.983 standard, where the downstream wavelength is at 1550nm and upstream wavelength at 1310nm.

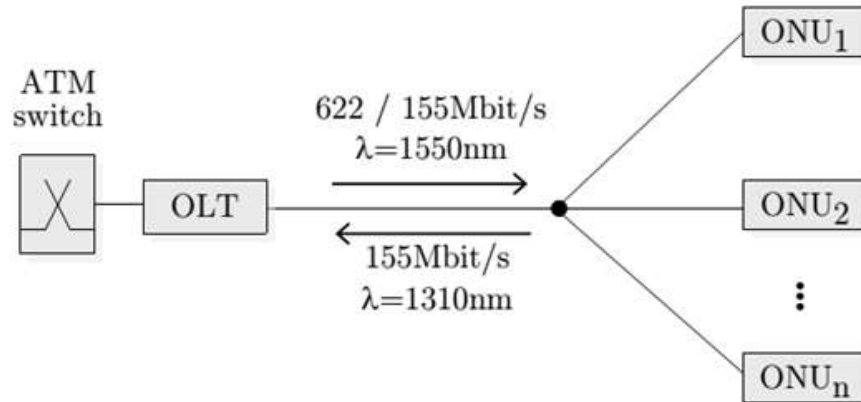

Figure 3-7: Typical APON network according to ITU-T G.983

BPON (formerly APON) as its name implies uses ATM protocol so it is limited to 622 Mb/s downstream and 155 Mb/s upstream according to ITU-T G.983.x. Table 3-4 lists description of ITU-T G.983.x BPON standard as shown in table 3-4.

Table 3-4: BPON Standards [41]

| ITU Recommendation | Features | Description |
|--------------------|----------------------------------|---|
| G.982 : | PON requirements and definitions | |
| G.983.1 : | 155 Mbps BPON | Specifies 155/155 Mbps and 655/155 Mbps system for 20 Km |
| G.983.2 : | management and control interface | ONT management and control support for data, voice and video |
| G.983.3 : | WDM for additional services | Enhanced wavelength plan to allow WDM expansion including the addition of video |
| G.983.4 : | DBA | Improves upstream bandwidth with DBA |
| G.983.5 : | enhanced survivability | Protection for BPON systems |

| ITU Recommendation | Features | Description |
|--------------------|---|---|
| G.983.6 : | OMCI specification for BPON system with protection Features | Enhancement to G.983.2 to support protected BPON systems. |

Wavelength assigned to APON/BPON for one fiber connected to each ONT for both upstream and downstream and for two fibers to each ONT, one for each direction

Table 3-5: Wavelength assigned to APON/BPON [42]

| | One fiber connection | Two fiber connection |
|--------------------|------------------------|------------------------|
| Downstream channel | $\lambda=1480-1500$ nm | $\lambda=1260-1360$ nm |
| Upstream channel | $\lambda=1260-1360$ nm | $\lambda=1260-1360$ nm |
| Video | $\lambda=1550-1560$ nm | $\lambda=1550-1560$ nm |

3.3.2. Ethernet PON

Ethernet PON (EPON) provides an IP data network that encapsulate data in Ethernet Frame then Ethernet protocol IEEE 802.3 frame is the base for EPON but can not be used as it is because IEEE 802.3 is multipoint-to-multipoint (MP2MP) protocol it is modified to serve P2MP connectivity. The EPON downstream channel uses true broadcast (see figure 3-9), while the upstream channel uses time slicing with no collisions and no packet fragmentation (see figure 3-10).

- Ethernet in the first mile standard 802.3ah/ITU G.984 with Downstream 1490 nm, and Upstream 1310 nm
- 10G-PON standard 802.3av/ITU G.987 with Downstream from 1260 nm to 1280 nm, and Upstream from 1575 to 1580 nm.

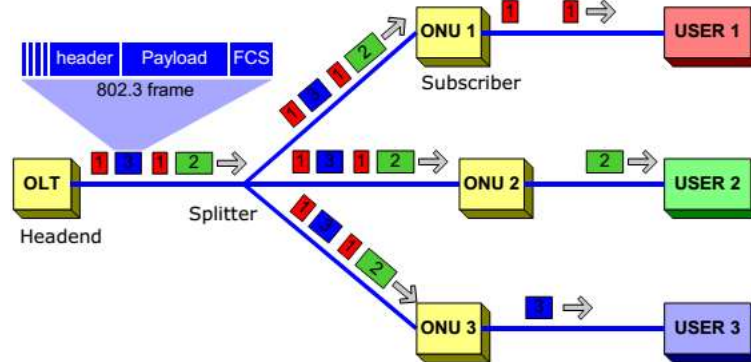

Figure 3-8: EPON downstream [43]

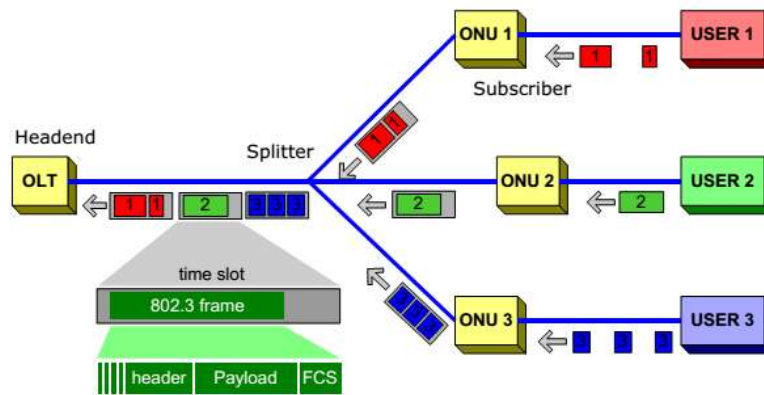

Figure 3-9: EPON upstream [45]

3.3.3. Gigabit PON

Gigabit PON (GPON) offers high bit rates of > 1 Gb/s according to the FSAN ITU standard G.984.x. GPONs are ideally suited for carrying both Ethernet/IP traffic and legacy voice and video services (see table 3-6). the OLT at CO combines Data, voice and video signals then direct the combined signals to fiber cables to the ODN that distributes the signals to users ONUs (see Figure 3-11).

Table 3-6: GPON sub-standards

| | |
|-----------|----------------------------------|
| G.984.1 : | GPON general characteristics |
| G.984.2 : | Physical Media Dependent layer |
| G.984.3 : | Transmission Convergence layer |
| G.984.4 : | Management and Control interface |

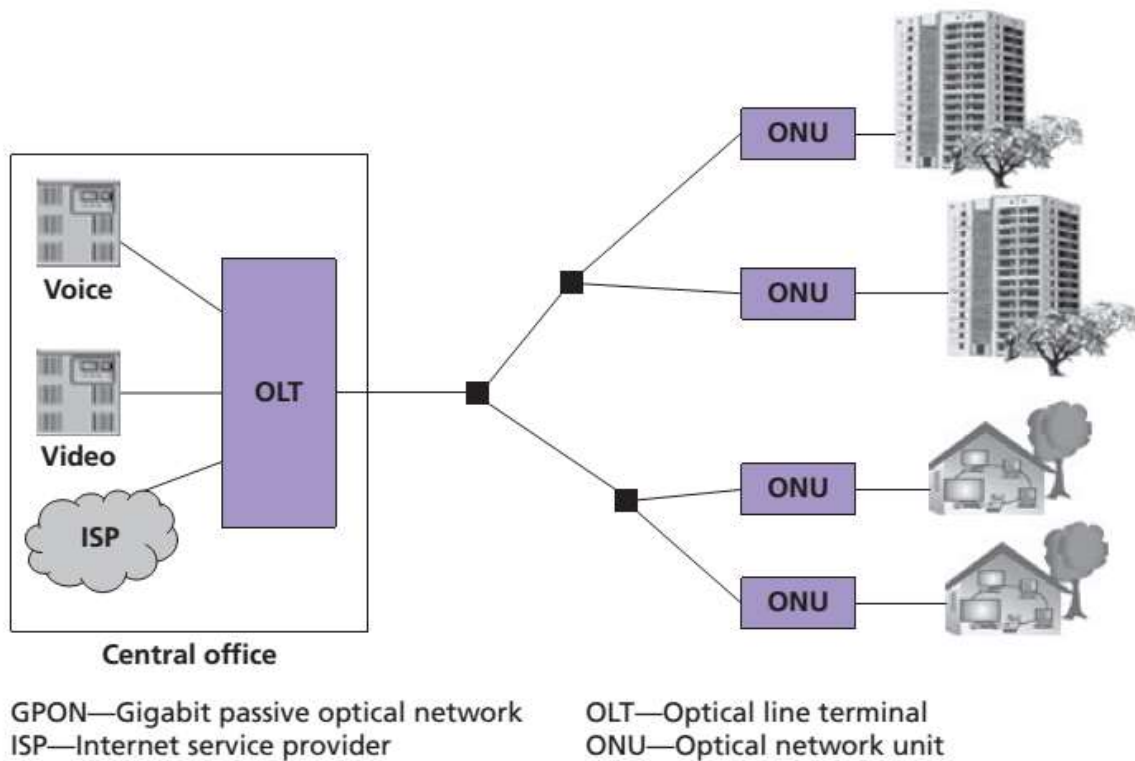

Figure 3-10: GPON architecture [44]

3.3.4. WDM PON

The previous implementations have bandwidth limitation due to the use of TDMA approach and OLT and ONU have to work at aggregate bit rate, this problem can be solved using WDM in which ONUs assigned individual wave lengths to provide higher bandwidth. WDM-PON can be implemented in either static WDM-PON or dynamic wavelength routed WDM-PON where the shared link carry all upstream and downstream wavelengths while the Multiplexer / Demultiplexer (Mux/DeMux) split individual upstream and down stream pairs for each of the ONUs.

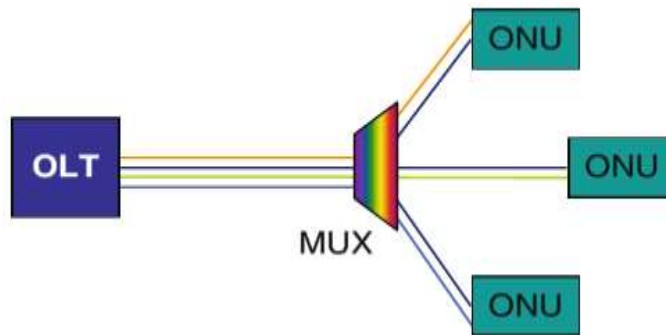

Figure 3-11: WDM-PON [45]

3.3.5. NG-PON

FSAN/ITU-T the PON approaches can be divided mainly to legacy G-PON standardized at 2009, short term evolution NG-PON1 (XG-PON) standardized since 2010 and NG-PON2 which is considered medium-term evolution initiated standardization at mid 2013 with time limit upto 2015 (see figure 3-13).

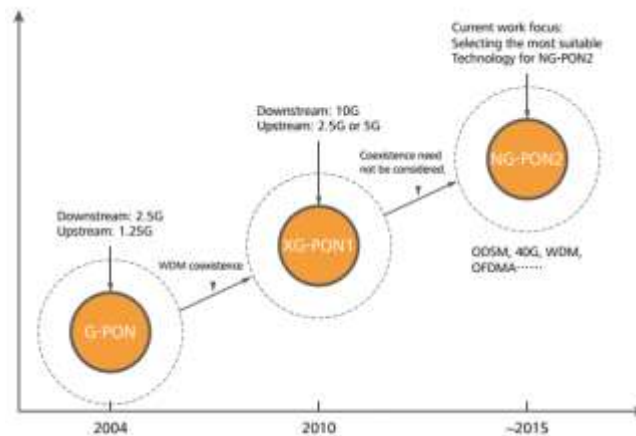

Figure 3-12: NG-PON roadmap by FSAN [46]

The NG-PON2 network can be implemented in different structures including OSDM-PON, TWDM-PON and stacked XG-PON.

3.3.5.1. OSDM-PON

Opportunistic and dynamic spectrum management PON (OSDM-PON) is silent solution that changes only OLT while keeping ODN and ONUs unchanged as it uses old CO WDM splitter in the ODN so it is considered cost efficive solution .

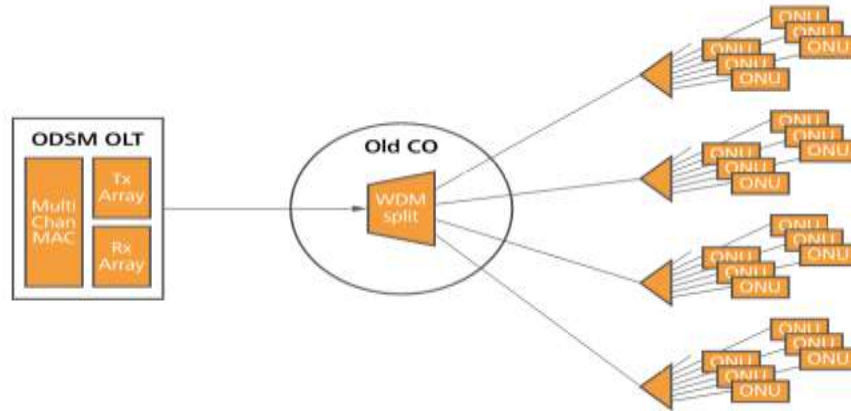

Figure 3-13: OSDM-PON

3.3.5.2. TWDM-PON

TWDM approach was selected to implement NG-PON2 to save operator investments in the outside planet (ODN) and limit changes only to terminal devices OLT and ONU [47].

NG-PON2 enable operators to offer several services over one network as follows ; residential broadband access, business services , mobile back-hauling and support dedicated point-to-point links – via a WDM overlay

TWDM is simply sending time division multiplexed data over wavelength division multiplexed channel. Figure 3-16 illustrates the basic diagram of TWDM-PON [48]

TWDM-PON is recommended by FSAN to be used to get aggregated bandwidth upto 100Gbps [49].

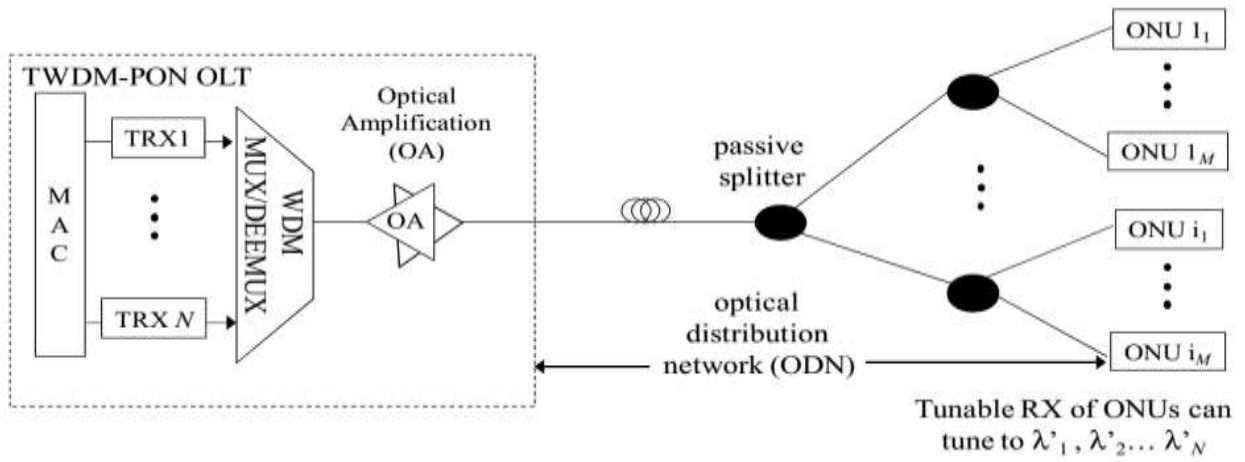

Figure 3-14 : Schematic diagram of TWDM-PON [50].

3.3.5.3. Stacked XG-PON

Implementation is which multiple XG-PON1 subnetworks share single ODN using WDM (see figure 3-15). Unlike ODSM-PON, the Stacked XG-PON implementation requires replacing ONUs by coloured ONUs.

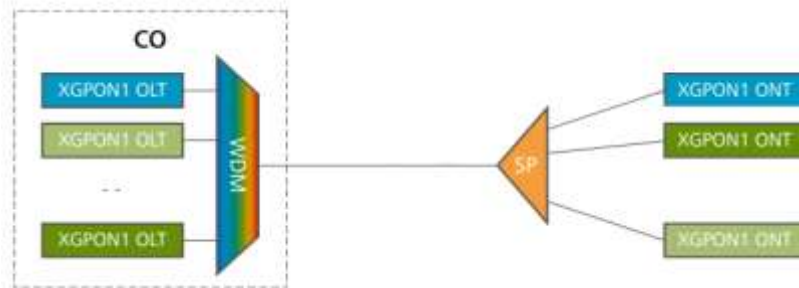

Figure 3-15: Stacked XGPON

Chapter 4: Designing of a TWDM NG-PON2

4.1.Introduction

In this chapter NG-PON2 based on TWDM is designed, implemented and tested for both aggregated 40 Gbps and 80 Gbps. The network design is modular that it can be repeated for more bandwidth. Key technologies required to develop next generation optical networks is discussed thoroughly. Figure (30) explains the mechanism of ONU wavelength management by OLT [51].

4.2.Key Technology

The implementation of TWDM NG-PON2 network is a great challenge as the tunable transceivers technology is still evolving with currently high cost that limits spreading this technology but this will change in the near future. The tunable transmitter and receiver of the ONU request wavelength from the OLT that assigns the ONU free wavelength in three-way hand shake (see figure 4-1).

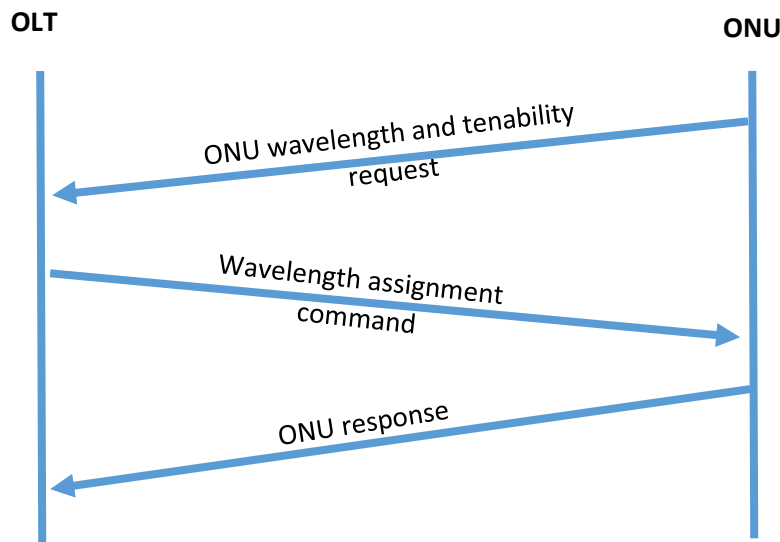

Figure 4-1: Wavelength management

4.2.1. Tuneable Transmitter

Tunable transmitters or tunable lasers is a challenge in the development of future ultra-high data rate networks. The transmitter can be fixed-tuned or dynamically-tuned. In previous generations of PON, many researchers studied wavelength tuning. Tuning in both time and wavelength is a promising technology for flexible NG-PON design.

There are many wavelength tuning techniques like: External cavity tunable lasers, Two-section tunable distributed Bragg reflector tunable laser diodes, Three-section tunable distributed Bragg reflector tunable laser diodes and One or two dimensional laser diode array [6]

4.2.2. Tuneable Receiver

It is vital to strictly select desired wavelength for data reception. The tunable receivers or Tunable Optical Filters (TOF) use an externally controlled electric signal to tune the filter to the selected wavelength with the following specifications; wide tuning range, fast tuning, constant gain, narrow bandwidth and stability against temperature variations.

There are many examples of tunable filters like the Fabry-Perot interferometer, the Bragg reflector, Dielectric thin-film interference, the Acousto-optic tunable optical filters (AOTFs), Tunable Mach-Zehnder filter, Absorption filters, Hybrid filters that combine different filter types. These types of filters vary in their characteristics and hence can be used for different applications.

As a comparison between predefined filters, it is found that acousto-optic and Fabry-Perot filters are better suited for a large number of channels applications, while electro-optic and semiconductor filters are better suited for fast tuning applications [52].

4.3.Related work

Many research done and have been published aiming to use TWDM-PON to design an access network according to NG-PON2 requirements. First work by Yuanqiu Luo, was published in February 2013. In this research the authors designed and tested a TWDM-PON for NG-PON2 by stacking four XG-PON2 using four pairs of wavelengths as $\lambda_1, \lambda_2, \lambda_3$ and λ_4 for upstream while $\lambda_5, \lambda_6, \lambda_7$ and λ_8 for downstream in the C-band, the downstream wavelengths are spaced 200 GHz and the aggregated bandwidth composed by multiplexing the individual downstream light signals using WDM Mux while the upstream wavelengths are spaced 100 GHz apart and split ratio 1:512 [53].

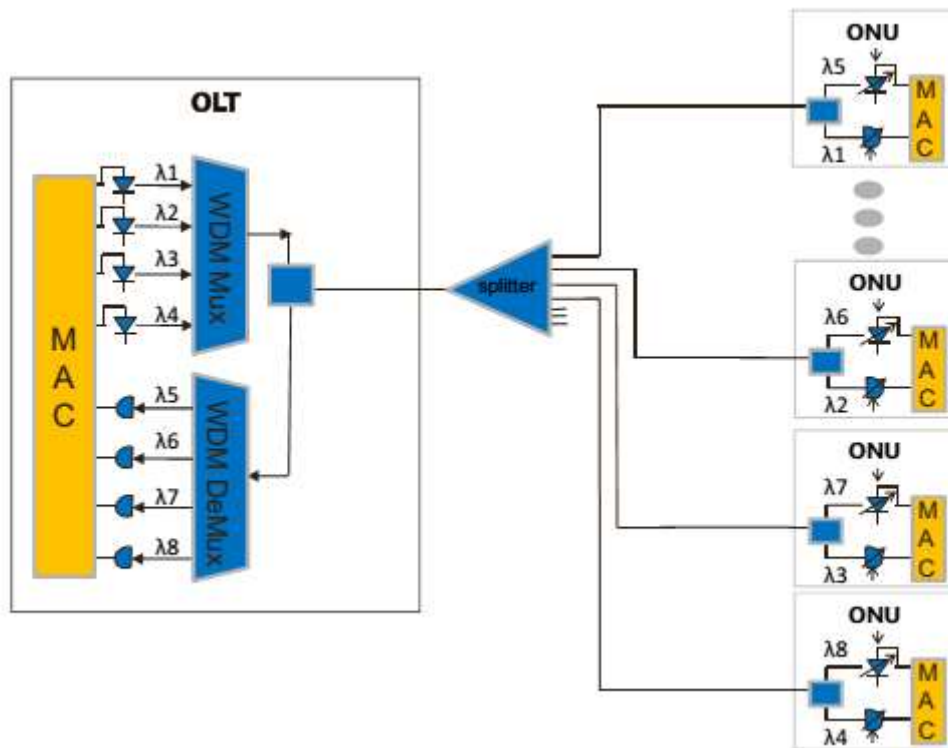

Figure 4-2: TWDM-PON system diagram [54].

4.4. System Architecture

The network consists mainly of TWDM OLT at the CO consists of four stacked XG-PON OLTs with different upstream and downstream wavelength pairs, ONU at user side and ODN to distribute the light signal to users sharing the aggregated bandwidth. The system is modular design that can be extended to 80 Gbps or more.

TWDM OLT is implemented by stacking four XGPONs with tunable transmitters and receivers for aggregate 40 Gbps the system in modular and can be upgraded by stacking eight XGPONs transievers of aggregate 80 Gbps.

OLT optical transmitter (see figure 4-3) consists of Pseudo-Random Bit Sequence (PRBS) Generator that generates the data stream to be transmitted followed by NRZ Pulse Generator. The line coded data modulates the optical light generated by CW Laser externally using Mach-Zehnder Modulator [55].

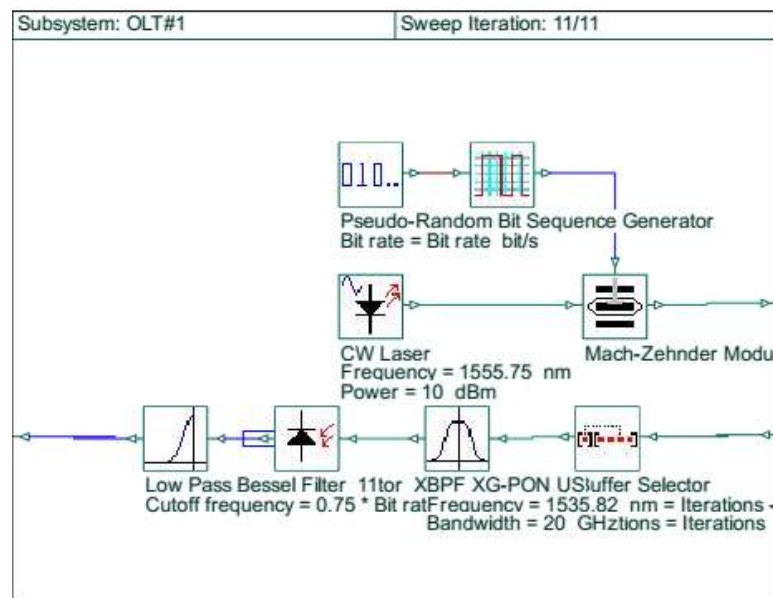

Figure 4-3: OLT for 10G-PON

Buffer Selector in OLT optical receiver gets all Time Division Multiple Access (TDMA) upstream data transmitted from all ONUs transmitting on the same wavelength. This wavelength is to be selected using band-pass filter then low cost photodiode can be used to recover the data received.

Optical transmitters are multiplexed using AWG that works as multiplexer while received optical signal is demultiplexed using AWG that works as demultiplexer and distribute each optical wavelength to its destination OLT receiver (see figure 4-4).

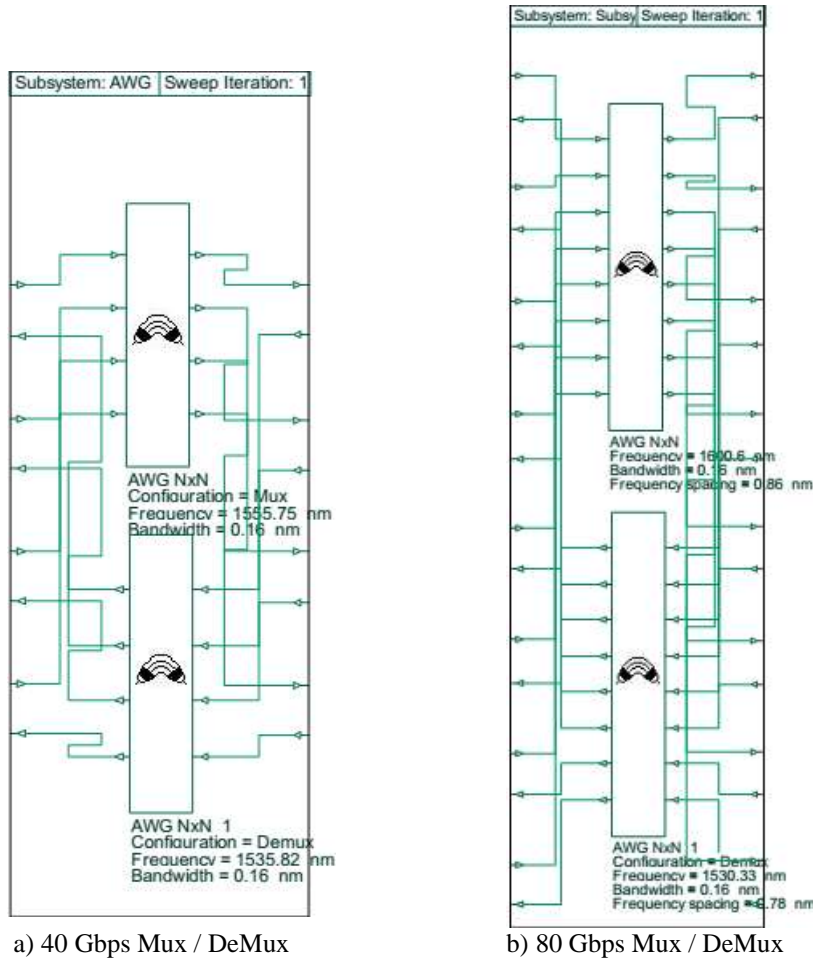

Figure 4-4: AWG Mux / DeMux a) 40 Gbps b) 80 Gbps

Then multiplexed signal output from the Mux carry data with aggregate 40 Gbps or 80 Gbps are directed to ODN through Single Mode Fiber (SMF) .

Optical distribution network (ODN) consists of two stages of power splitters; 1:8 passive splitter / combiner (see figure 4-5 a) followed by 1:16 splitter / combiner (see figure 4-5 b) to get 128 split ratio can be upgraded to 256 split ratio using either 1:16 followed by 1:16 or 1:8 followed by 1:32 taking into consideration power budget calculations.

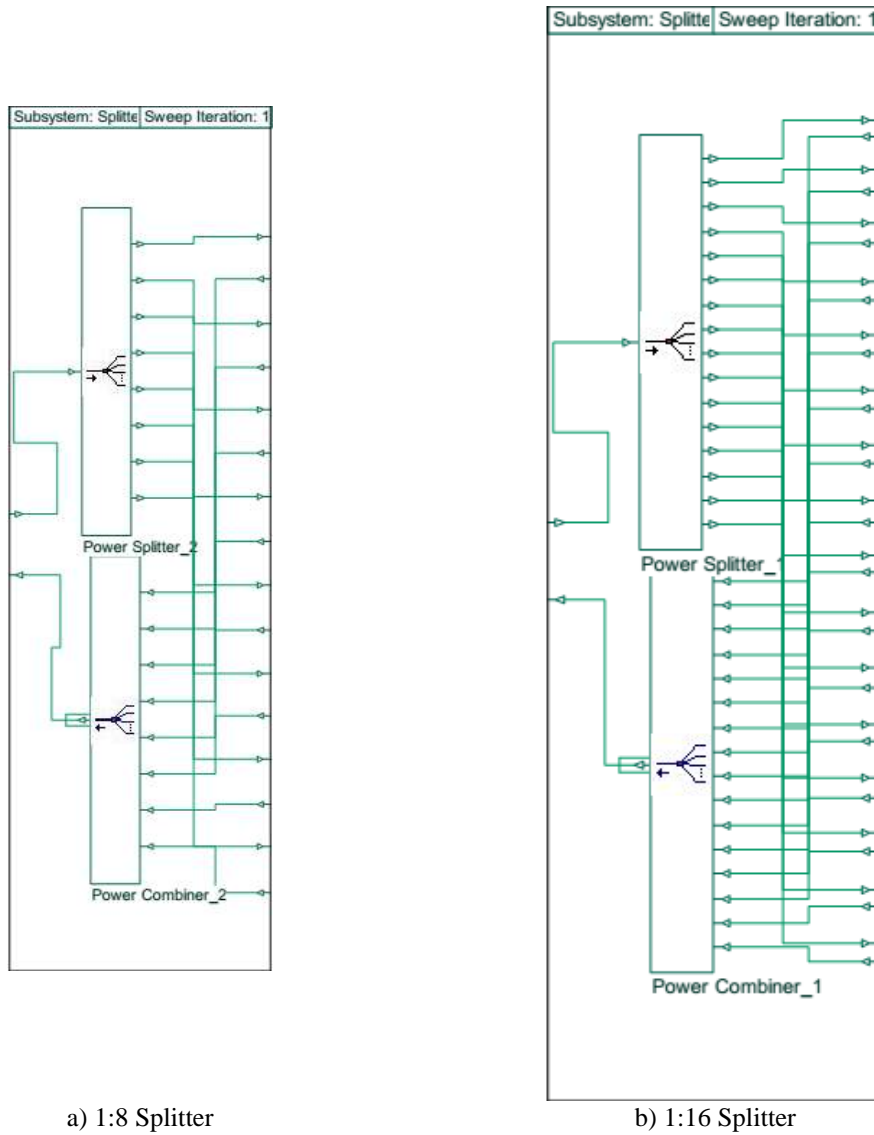

Figure 4-5: passive Splitter / Combiner

Optical Network Terminal consists of tunable transmitter and receiver, the transmitter consists of WDM transmitter that can tune to required upstream wavelength and uses two stages of Dynamic Y select for dynamic time slot management to transmit burst of data only in the required time slot of transmission. Time slot assignment is controlled by OLT.

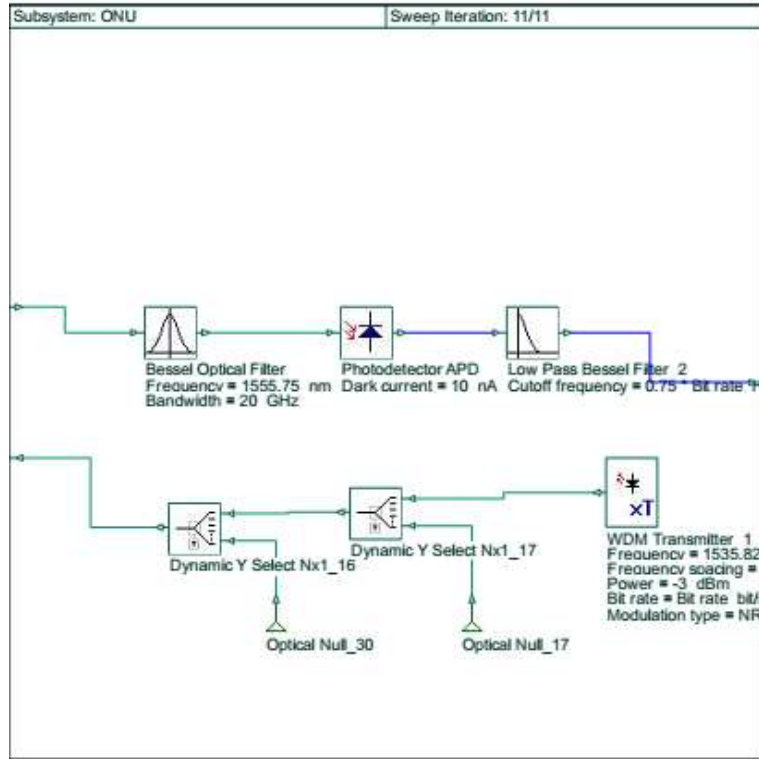

Figure 4-6: ONU Unit

In the network design in this thesis work 16 ONUs (see figure 4-7) share the same wavelength and but with different time slots, according to split ratio of the second splitter stage the ONUs are connected to the splitter.

The formula for the Dynamic Y Select 1 for 16 time slots is given by

$$\text{Switching Event Time} = \text{TimeSlot} \times \frac{1}{\text{Bit rate}} \times \frac{\text{Sequence length}}{16} \quad (4-1)$$

The formula for the Dynamic Y Select 2 is given by

$$\text{Switching Event Time} = \text{TimeSlot} \times \frac{1}{\text{Bit rate}} \times \frac{\text{Sequence length}}{16} \times \frac{\text{Time window}}{16} \quad (4-2)$$

For Bit rate of 10 Gbps and Sequence length 256 bit and 25.6 ns time window the switching event calculated as shown in table 4-1. This divides the 10 Gbps data loaded to the optical light signal shared by 16 user so the 40 Gbps network can serve 64 user with dedicated 640 Mbps for each user while the 80 Gbps implementation serves 128 user with the same data rate. Both systems can serve more users with less than 640 mbps taking into consideration the power budget for higher split ratio

Table 4-1 : Switching Event for 16 users

| ONU | time Solt | TimeSlot * (1/Bit rate) *Sequence length / 16 | TimeSlot * (1/Bit rate) *Sequence length / 16 + Time window/16 | BitRate | 10.0E+9 |
|-----|-----------|---|--|-----------------|---------|
| | | Dynamic Select 1 | Dynamic Select 2 | sequence Length | 256 |
| 1 | 0 | 000.0E+0 | 1.6E-9 | Time Window | 25.6E-9 |
| 2 | 1 | 1.6E-9 | 3.2E-9 | | |
| 3 | 2 | 3.2E-9 | 4.8E-9 | | |
| 4 | 3 | 4.8E-9 | 6.4E-9 | | |
| 5 | 4 | 6.4E-9 | 8.0E-9 | | |
| 6 | 5 | 8.0E-9 | 9.6E-9 | | |
| 7 | 6 | 9.6E-9 | 11.2E-9 | | |
| 8 | 7 | 11.2E-9 | 12.8E-9 | | |
| 9 | 8 | 12.8E-9 | 14.4E-9 | | |
| 10 | 9 | 14.4E-9 | 16.0E-9 | | |
| 11 | 10 | 16.0E-9 | 17.6E-9 | | |
| 12 | 11 | 17.6E-9 | 19.2E-9 | | |
| 13 | 12 | 19.2E-9 | 20.8E-9 | | |
| 14 | 13 | 20.8E-9 | 22.4E-9 | | |
| 15 | 14 | 22.4E-9 | 24.0E-9 | | |
| 16 | 15 | 24.0E-9 | 25.6E-9 | | |

Figure 4-7 shows the second split stage composed of 1:16 splitter / Combiner connected to 16 ONUs that share the data frame

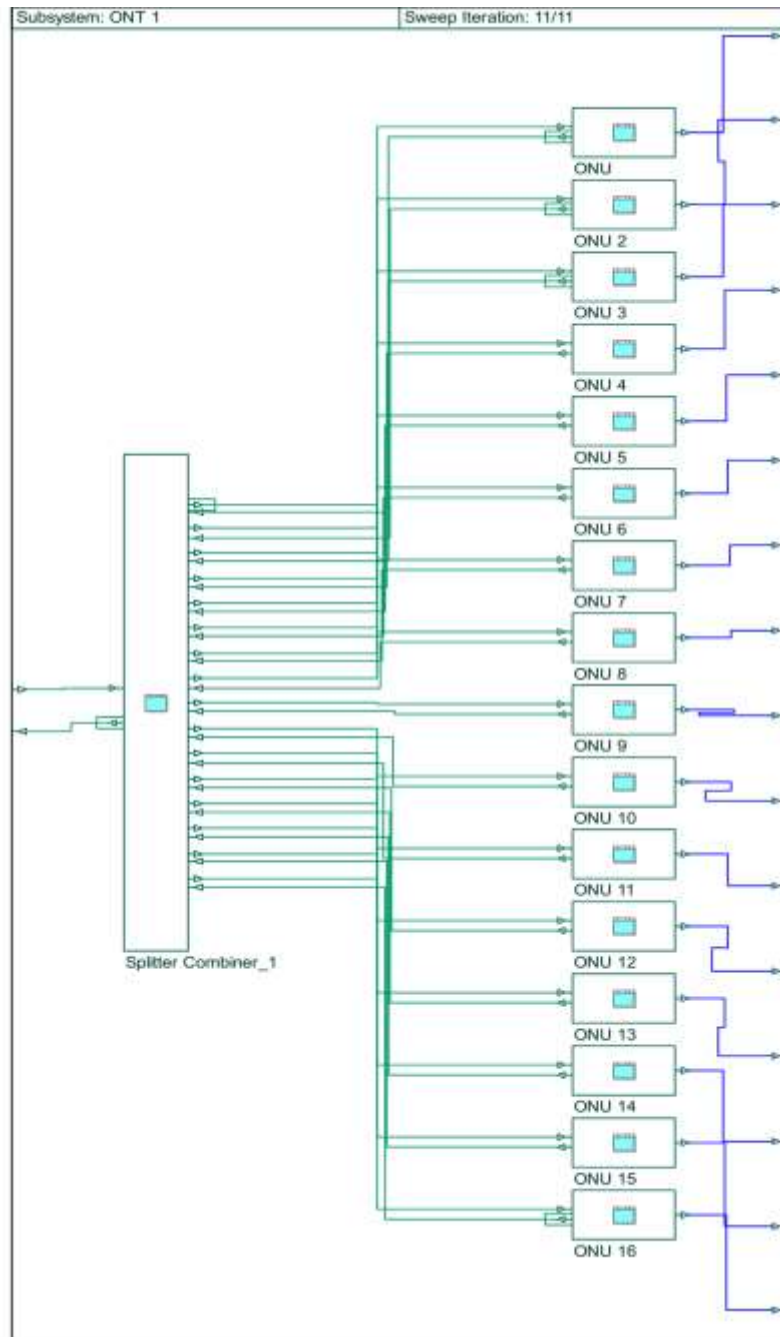
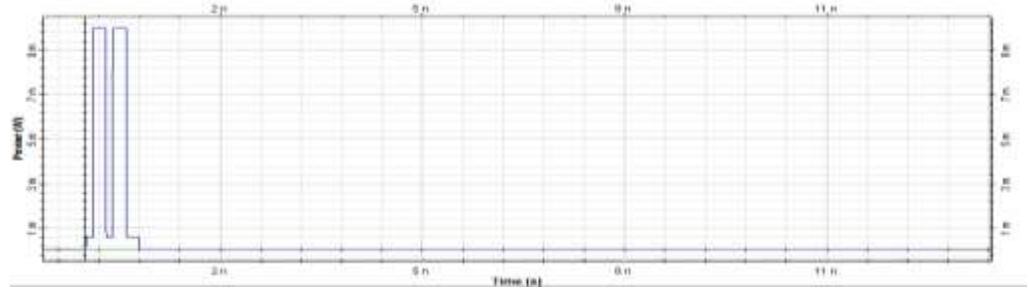

Figure 4-7: Schematic second splitter with 16 ONUs

The output data from each ONU alligned to the time slots in table 4-1 are shown in figure 4-8, the whole frame and sample time slots TS 0 (see figure 4-4 a), TS 1 (see figure 4-4 b)and TS 15 (see figure 4-4 c) the whole frame with 16 time slots is shown in figure 4-4 d.

a) TS 0



b) TS 1

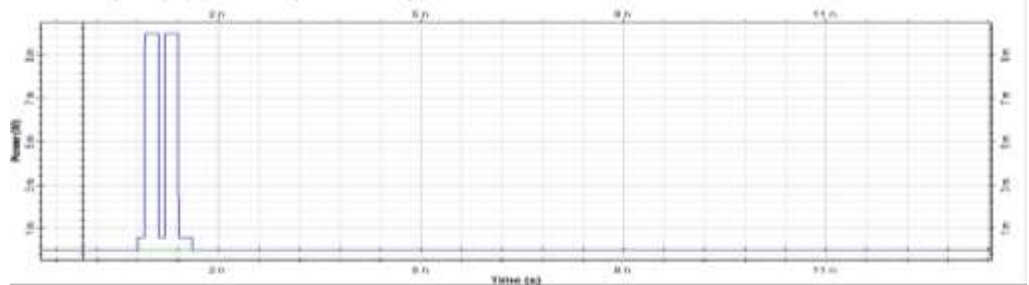

c) TS 15

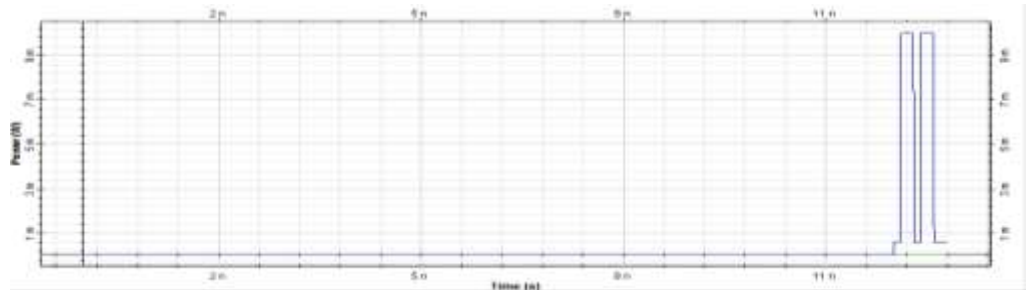

d) Frame

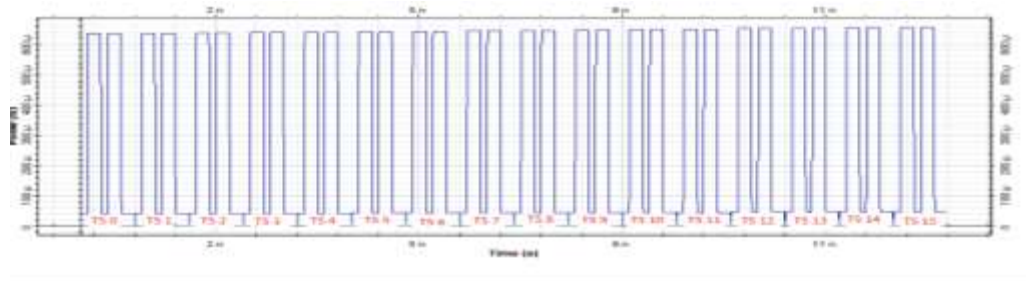

Figure 4-8: Time Slots for 16 users

4.5.40 GB/S TWDM-PON System Prototype

The 40 Gbps network can be implemented by stacking four XG-PONs (see figure 4-9) with four downstream/upstream wavelength pairs $\{\lambda_1, \lambda_2, \lambda_3, \lambda_4\}$ for downstream data signals and $\{\lambda_5, \lambda_6, \lambda_7, \lambda_8\}$ for upstream data signals.

The data signals from each Internet Service Provider (ISP) is sent to the appropriate OLT, then the data modulates the light signal with downstream light signal with wavelength specified by the MAC layer protocol, the data from each transmitter are combined by WDM mux then lunched to the optical fiber for transmission and reach the passive splitter for distribution to users ONUs.

In the upstream direction the user data modulates the upstream light signal with wavelength and time slot specified also by MAC layer protocol, wavelength and time slot are Negotiated through link setup.

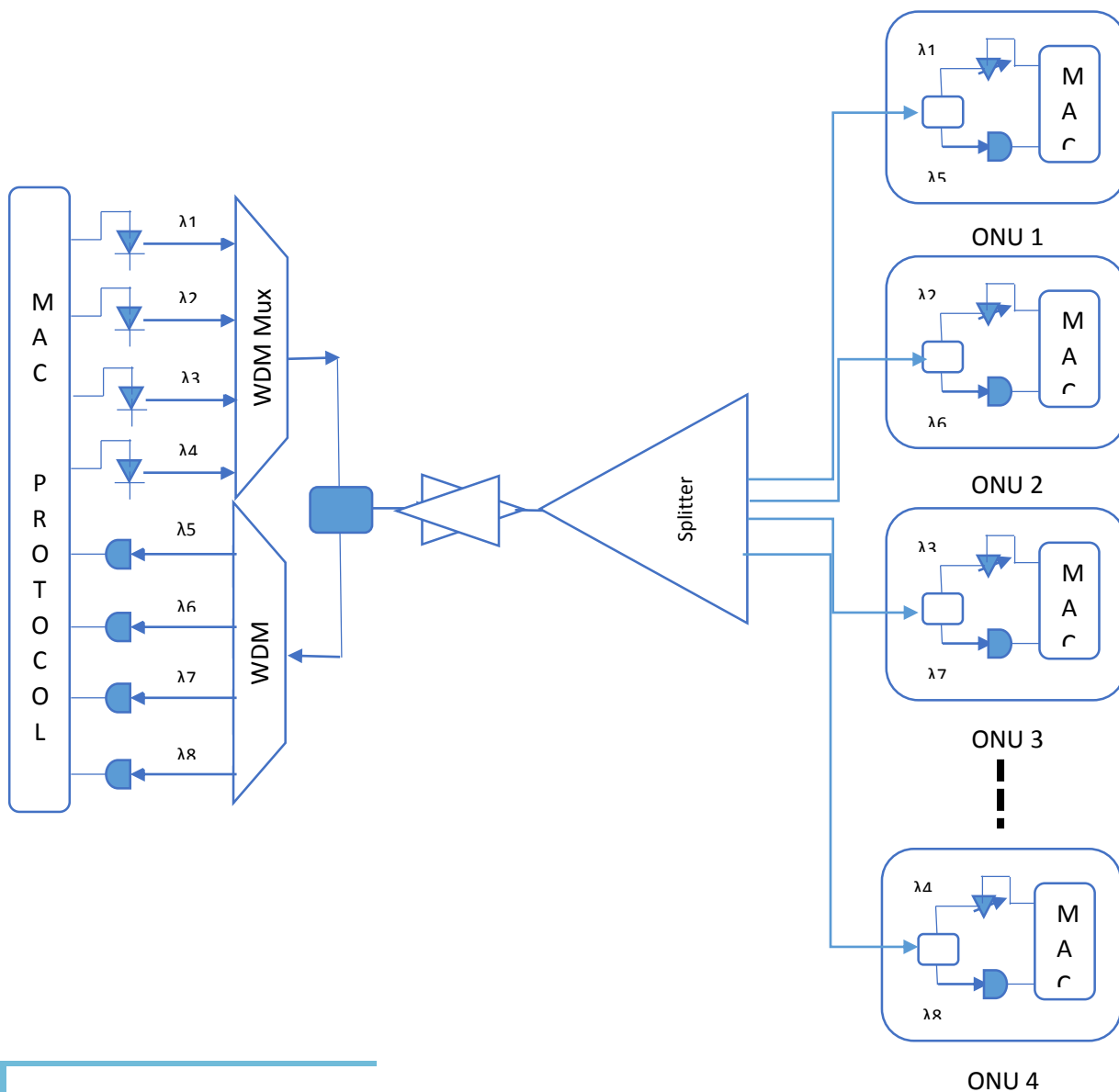

Figure 4-9: 40 Gbps TWDM NG-PON2 system architecture

The network design is implemented and tested using optiwave optisystem design tool for 40 Gbps distributed and serving 64 users (see figure 4-10).

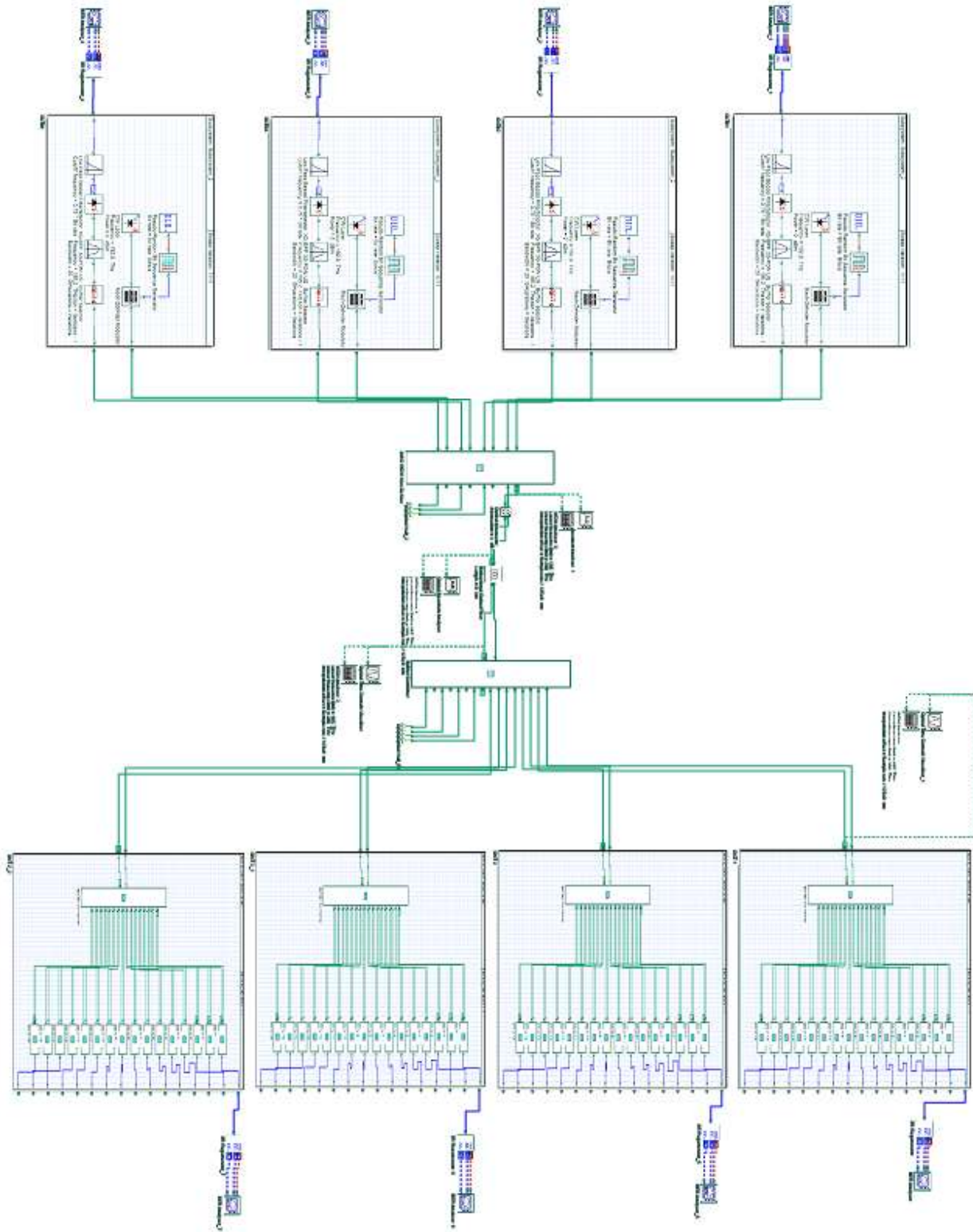

Figure 4-10: 40 Gbps TWDM NG-PON2 system architecture - Optisystem implementation

The system design parameters of OLT and Mux / DeMux for 40 Gbps TWDM NG-PON2 listed (see table 4-2 and table 4-3). Table 4-2 shows that the downstream bitrate for one of the four XG-PONs used is 10 Gbps with Non Return to Zero (NRZ) line coding format and the power lunched sweep the value between -10 dBm and 10 dBm, the downstream wavelengths are 1555.75 , 1556.55 , 1557.36 , 1558.17 nm while the upstream wavelengths are 1535.82 , 1536.61 , 1537.4 , 1538.19 nm with extinction Ratio 10 for Mach-Zehnder-Modulator (MZM).

Table 4-3 shows the that the first downstream (DS) channel of AWG Mux is at 1555.75 nm with spacing 0.81, this leads to channel 2 is at 1556.56, channel 3 is at 1557.37 and channel 4 is at 1558.18, while the first Upstream (US) channel of AWG DeMux is at 1535.82 nm with spacing 0.79, this leads to channel 2 is at 1536.61, channel 3 is at 1537.4 and channel 4 is at 1538.19.

Table 4-2: system design parameters

| Component | Parameter | Value |
|------------------------|-----------------|--|
| PRBS generator | Bit rate | 10 Gbps |
| Pulse Generator | Line coding | NRZ |
| Downstream CW Laser | Power | -10 to 10 dBm (for testig purpose) |
| | Wavelengths | 1555.75 , 1556.55 , 1557.36 , 1558.17 nm |
| Upstream CW Laser | Wavelengths | 1535.82 , 1536.61 , 1537.4 , 1538.19 nm |
| MZM external Modulator | Extintion Ratio | 10 |

Table 4-3: Parameters of 40 Gbps Mux and DeMux

| Component | Parameter | Value |
|-----------|-----------|------------|
| AWG Mux | frequency | 1555.75 nm |
| | Bandwidth | 0.16 |
| | spacing | 0.81 |
| AWG DeMux | frequency | 1535.82 nm |
| | Bandwidth | 0.16 |
| | spacing | 0.79 |

4.5.1. Wavelength Plan for 40 Gbps prototype

Choosing wavelength range depends on several factors like fiber type, optical source characteristics, system attenuation range and dispersion occurs in the optical path. There are many wavelength plans that can be implemented (see figure 4-11), each plan has its advantages and disadvantages considering co-existence with current working systems[53].

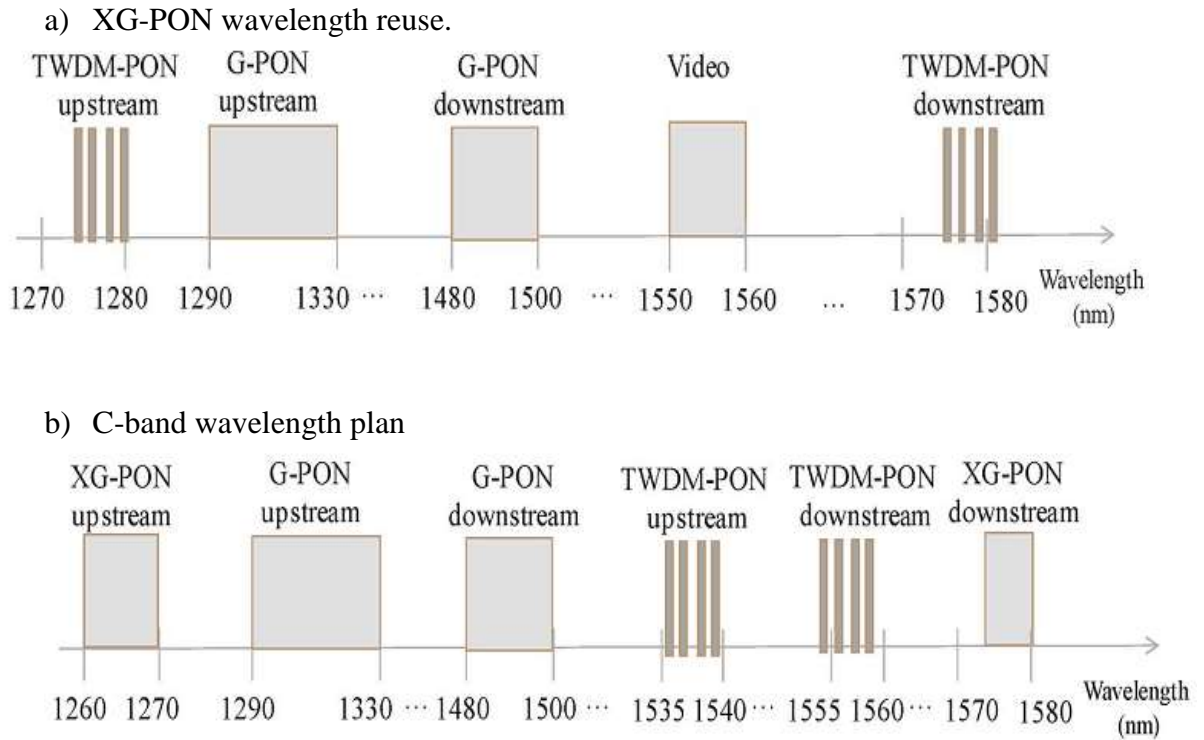

Figure 4-11: Wavelength Plan options for 40 Gbps

Option a) reuses XG-PON wavelengths so TWDM PON can coexist with GPON and Video services but can not coexist with XGPON on the same fiber.

Option b) C-Band is selected as TWDM PON can coexist with GPON XGPON but video services is no longer available on 1555 nm.using option b service providers can use pay as you grow strategy for smooth upgrade.

The values of downstream light wavelengths measured by WDM analyzer immediately after AWG Mux for 40 Gbps TWDM-PON are shown in table 4-4 , the same signals from spectrum analyzer are show in figure 4-12.

Table 4-4: downstream wavelengths – WDM analyzer for 40 Gbps TWDM-PON

| Wavelength (nm) | Signal Power (dBm) |
|-----------------|--------------------|
| 1558.17 | 5.5360323 |
| 1557.36 | 5.7935024 |
| 1556.55 | 5.460562 |
| 1555.75 | 5.7222542 |

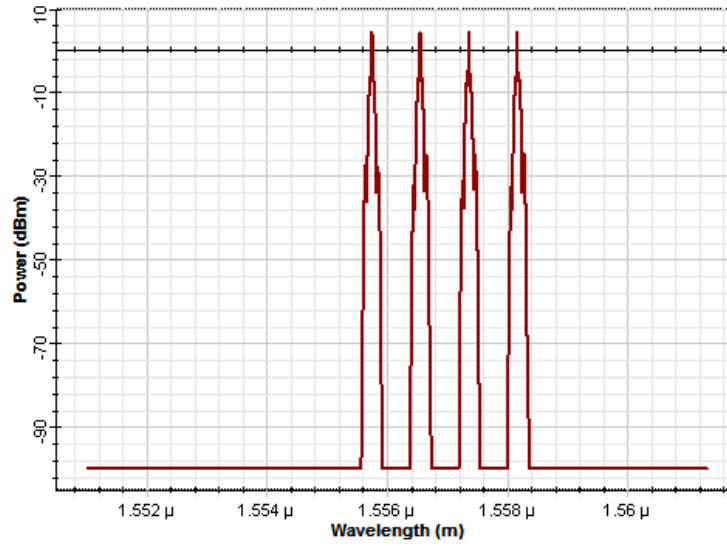

Figure 4-12: downstream wavelengths – spectrum analyzer for 40 Gbps TWDM-PON

The values of upstream light wavelengths measured by WDM analyzer at the connection between SMF cable and first splitter / combiner for 40 Gbps TWDM-PON are shown in table 4-5 , the same signals from spectrum analyzer are show in figure 4-13.

Table 4-5: upstream wavelengths – WDM analyzer for 40 Gbps TWDM-PON

| Wavelength (nm) | Signal Power (dBm) |
|-----------------|--------------------|
| 1538.19 | -35.572316 |
| 1537.4 | -35.351249 |
| 1536.61 | -35.386699 |
| 1535.82 | -35.325872 |

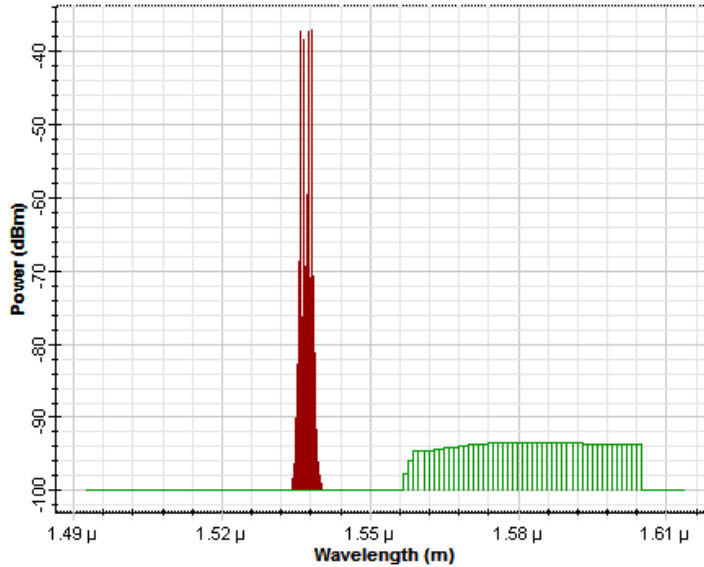

Figure 4-13: upstream wavelengths – spectrum analyzer for 40 Gbps TWDM-PON

4.5.2. Simulation Results (40 Gbps TWDM-PON)

The design is tested for variable parameters that shows good results for feasible implementation for wavelength 1555.75 nm at distance 40Km ; the measured values are 17.7629 Quality Factor (Q-Factor) (see figure 4-14), 6.414×10^{-71} Minimum Bit Error Rate (BER) (see figure 4-14), Eye diagram with opening showing high and width for good decision of incoming bits conclude that the system downstream is reliable , feasible and can be implemented without any problems..

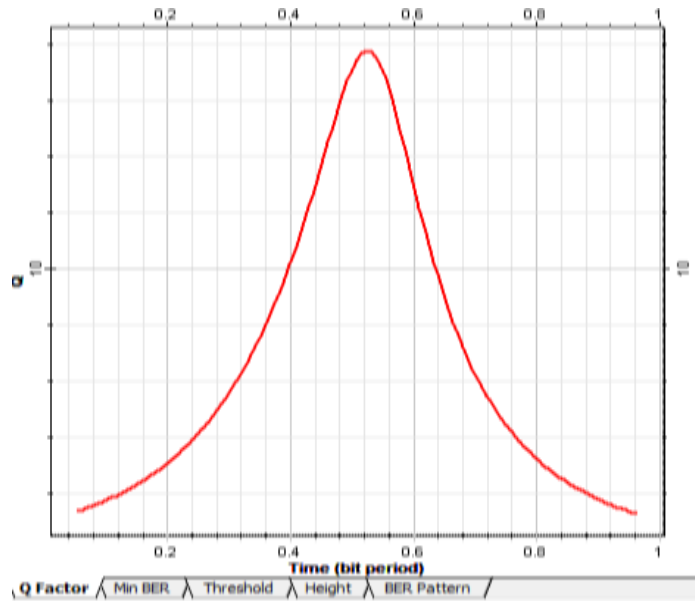

Figure 4-14: Q Factor for 1555.75 nm downstream at 40 Km

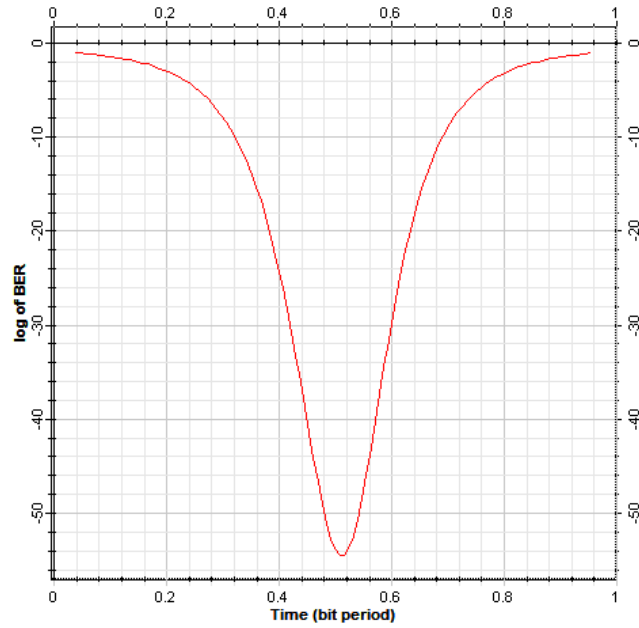

Figure 4-15: Min BER Diagram for 1555.75 downstream nm at 40 Km

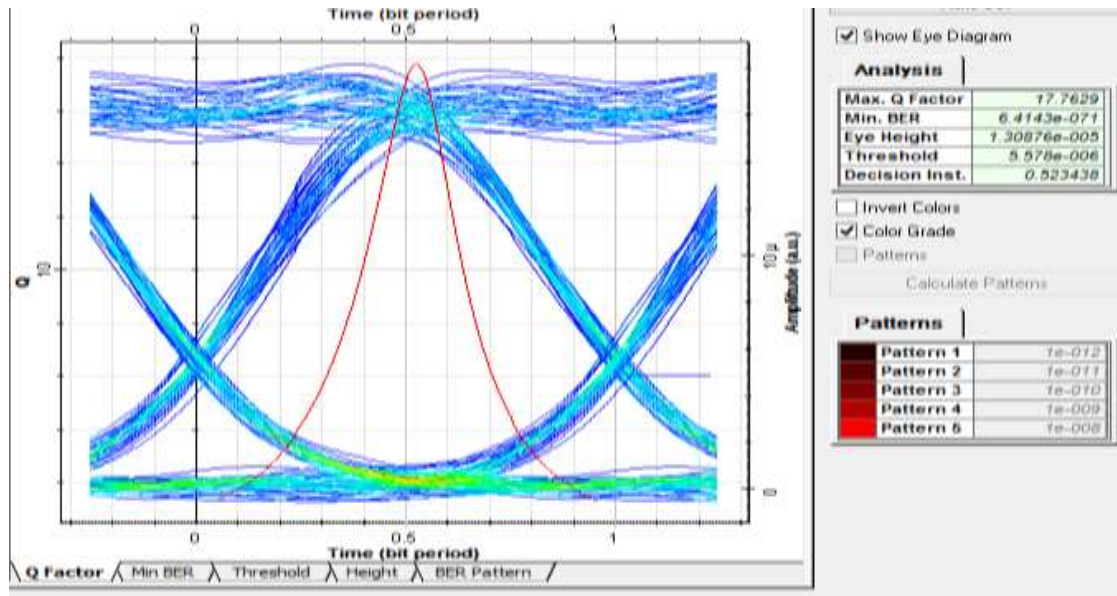

Figure 4-16: Eye Diagram for 1555.75 nm downstream at 40 Km

Figure 4-17 shows the receiver sensitivity for 1555.57 nm wavelength at distances Back to Back (B2B), 10 Km , 20 Km , 30 Km and 40 Km, the system has acceptable value of BER (less than 1×10^{-10}) at input power of 6 dBm lunched in the OLT transmitter at 40 Km reach while it can be accomplished for less than 40 Km reach with less laser power at OLT transmitter. Figure 4-18 shows that using any of the four wavelengths of transmitted by 40

Gbps TWDM-PON gets the same results except for some non-linearity in the 1557.36 nm and 1558.17 nm .

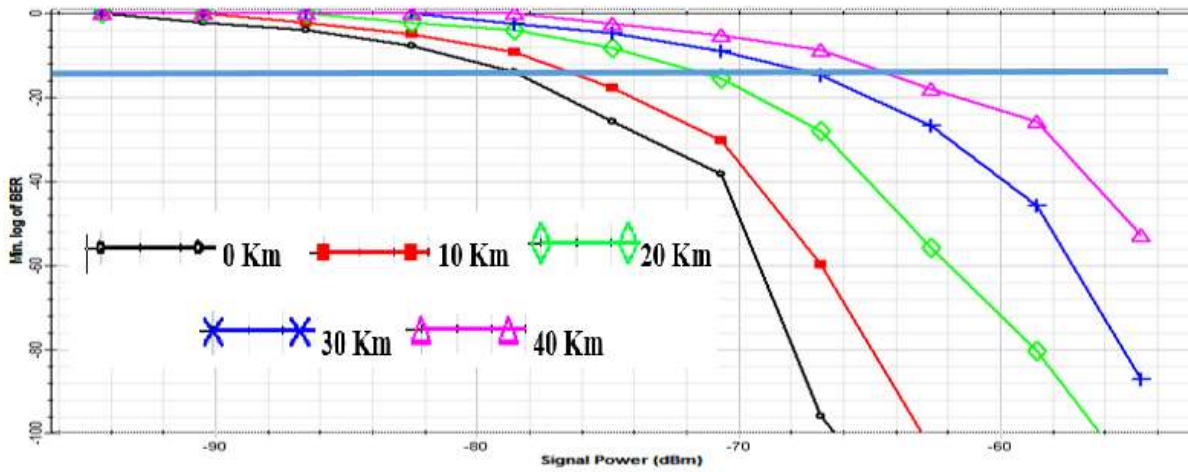

Figure 4-17: Receiver sensitivity for 1555.57 nm

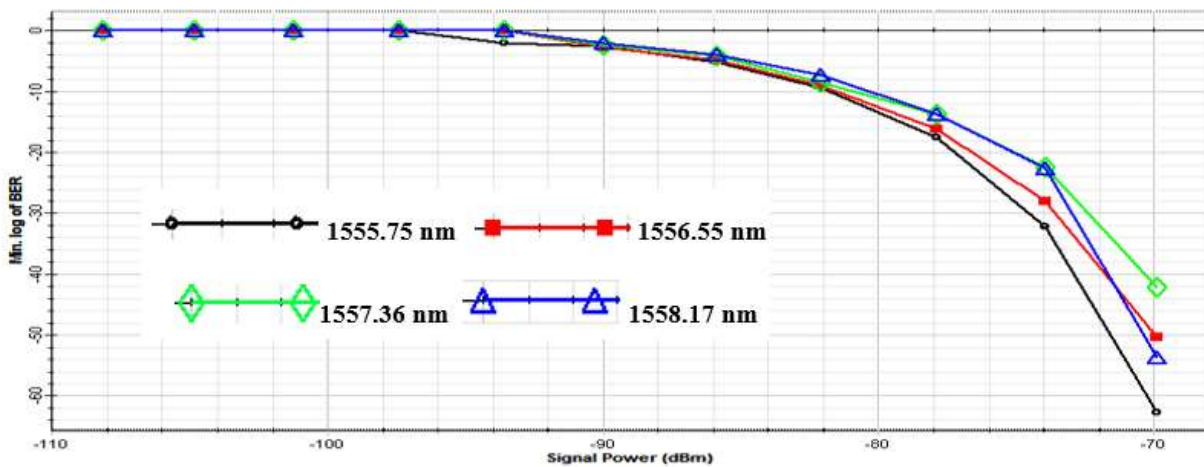
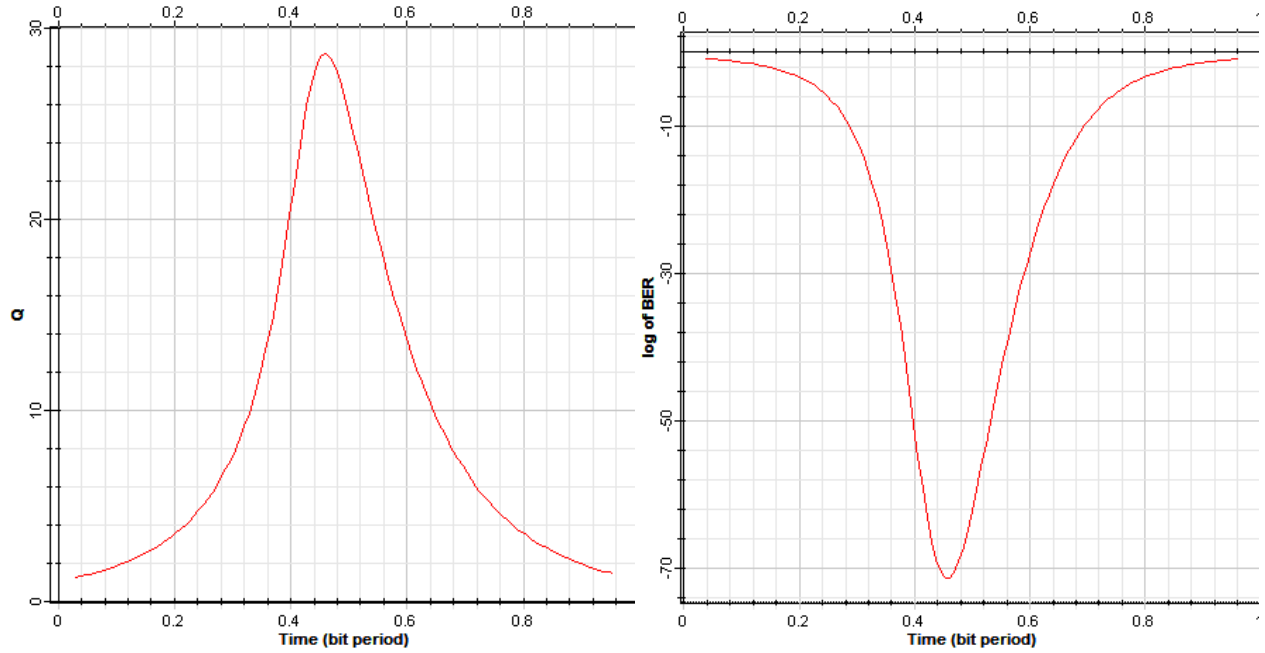

Figure 4 - 18: Receiver sensitivity at 40 Km

The upstream results can be described as; figure 4-19 a) identify 28.68 measured value for Q-Factor, while figure 4-19 b) shows very low BER value of 2.68×10^{-181} and figure 4-19 c) shows the Eye diagram with eye opening and high good for decision of data received , the three figures conclude that the upstream has the same behavior as downstream and illustrates that the system upstream also is feasible and hence the 40 Gbps TWDM-PON system serving 64 user at a maximum reach 40 Km in both is feasible to be implemented with no risk.



a) Q Factor for 1535.82 nm downstream at 40 Km

b) BER for 1535.82 nm downstream at 40 Km

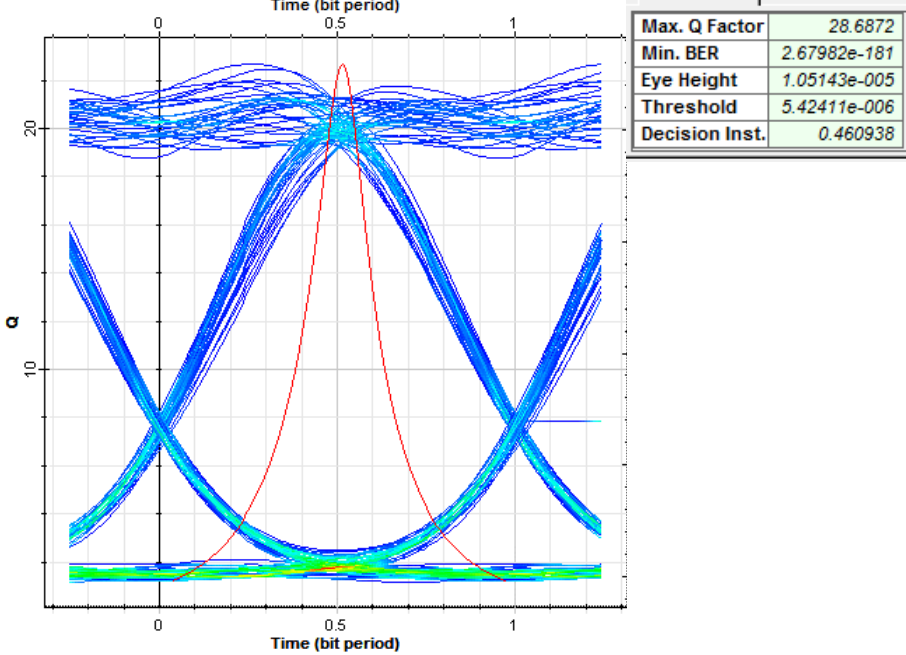

c) Eye Diagram for 1535.82 nm downstream at 40 Km

Figure 4-19: Q-Factor, Min BER and Eye diagram for 1535.82 nm upstream at 40 Km

4.6. 80 GB/S TWDM-PON Prototype

The 80 Gbps system is a duplicate of the 40 Gbps system but with another downstream wavelength band starting at 1600.6 nm.

The 80 Gbps network can be implemented by stacking eight XG-PONs (see figure 4-20) with eight downstream wavelengths $\{ \lambda_{1d}, \lambda_{2d}, \lambda_{3d}, \lambda_{4d}, \lambda_{5d}, \lambda_{6d}, \lambda_{7d}, \lambda_{8d} \}$ for downstream data and upstream wavelengths $\{ \lambda_{1u}, \lambda_{2u}, \lambda_{3u}, \lambda_{4u}, \lambda_{5u}, \lambda_{6u}, \lambda_{7u}, \lambda_{8u} \}$ for upstream data.

Identically the same as the 40 Gbps system, The data signals from each Internet Service Provider (ISP) is sent to the appropriate OLT, then the data modulates the light signal with downstream light signal with wavelength specified by the MAC layer protocol, the data from each transmitter are combined by WDM mux then launched to the optical fiber for transmission and reach the passive splitter for distribution to users ONUs.

In the upstream direction the user data modulates the upstream light signal with wavelength and time slot specified also by MAC layer protocol, wavelength and time slot are Negotiated through link setup.

The network design is implemented and tested using optiwave optisystem design tool for 80 Gbps distributed and serving 64 users (see figure 4-21).

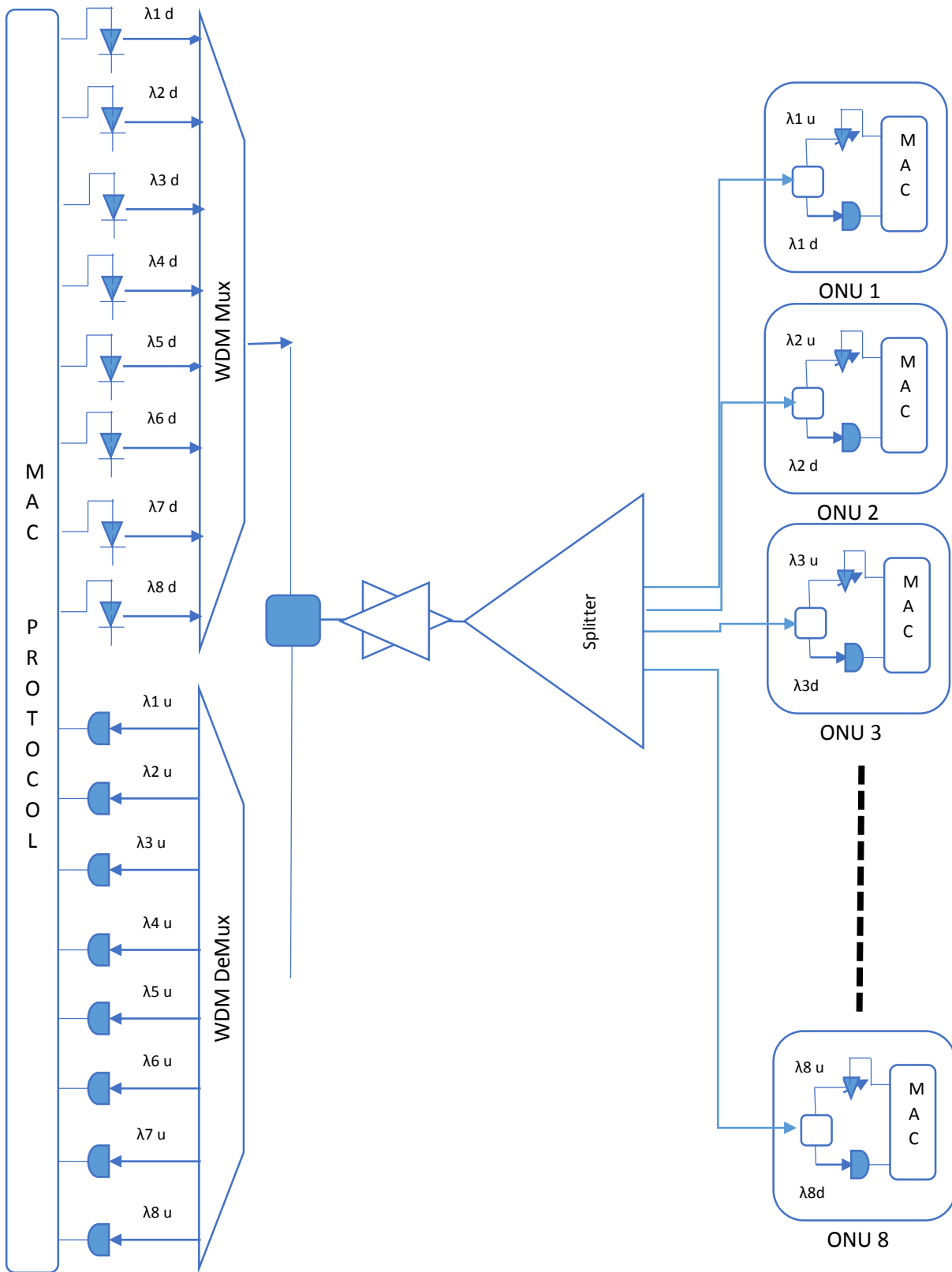

Figure 4-20: 80 Gbps TWDM NG-PON2 system architecture

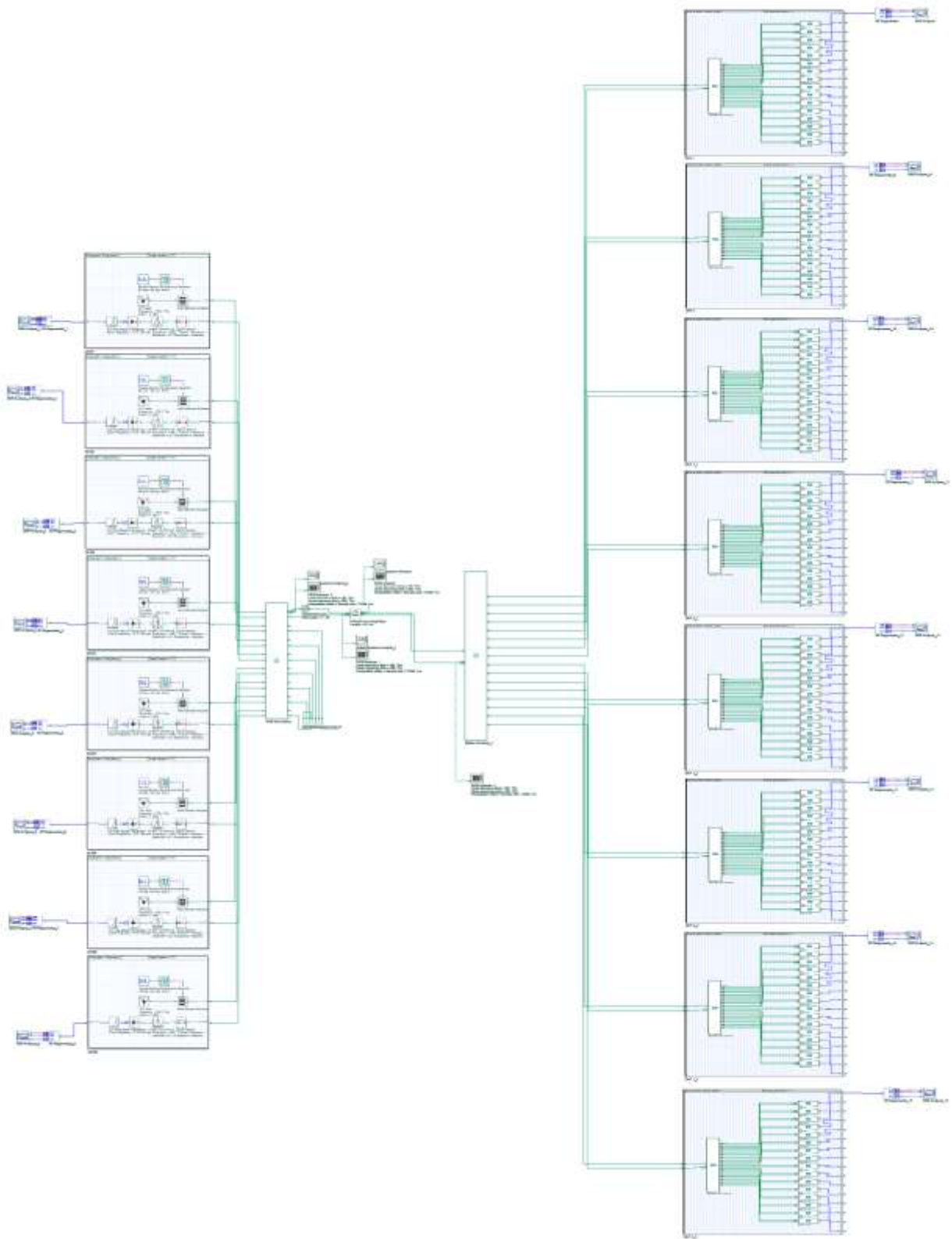

Figure 4-21: 80 Gbps TWDM NG-PON2 system architecture - Optisystem implementation

The system design parameters of OLT and Mux / DeMux for 80 Gbps TWDM NG-PON2 listed (see table 4-6 and table 4-7). Table 4-6 shows that the downstream bitrate for one of the eight XG-PONs used is 10 Gbps with NRZ line coding format and the power lunched sweep the value between -10 dBm and 10 dBm, the downstream wavelengths are 1600.6, 1601.46, 1602.31, 1603.17 , 1604.03, 1604.88, 1605.74, 1606.6 nm while the upstream wavelengths are 1530.33, 1531.12, 1531.9, 1532.68, 1533.47, 1534.25, 1535.04, 1535.82 nm with extinction Ratio 10 for MZM external Modulator.

Table 4-7 shows the that the first downstream (DS) channel of AWG Mux is at 1600.6 nm with spacing 0.86, this leads to channel 2 is at 1601.46 nm, channel 3 is at 1602.31 nm, channel 4 is at 1603.17 nm, channel 5 is at 1604.03 nm, channel 6 is at 1604.88 nm, channel 7 is at 1605.74 nm and channel 8 is at 1606.6 nm, while the first Upstream (US) channel of AWG DeMux is at 1530.33 nm with spacing 0.79, this leads to channel 2 is at 1531.12 nm, channel 3 is at 1531.9 nm, channel 4 is at 1532.68 nm, channel 5 is at 1533.47 nm, channel 6 is at 1534.25 nm, channel 7 is at 1535.04 nm and channel 8 is at 1535.82 nm.

Table 4-6: Parameters of 80 Gbps OLT

| Component | Parameter | Value |
|------------------------|-----------------|--|
| PRBS generator | Bit rate | 10 Gbps |
| Pulse Generator | Line coding | NRZ |
| Downstream CW Laser | Power | -10 to 10 dBm (for testig purpose) |
| | Wavelengths | 1600.6, 1601.46, 1602.31, 1603.17 , 1604.03, 1604.88, 1605.74, 1606.6 nm |
| Upstream CW Laser | Wavelengths | 1530.33, 1531.12, 1531.9, 1532.68, 1533.47, 1534.25, 1535.04, 1535.82 nm |
| MZM external Modulator | Extintion Ratio | 10 |

Table 4-7: Parameters of 80 Gbps Mux and DeMux

| Component | Parameter | Value |
|-----------|-----------|---------|
| AWG Mux | frequency | 1555.75 |
| | Bandwidth | 0.16 |
| | spacing | 0.86 |
| AWG DeMux | frequency | 1530.82 |
| | Bandwidth | 0.16 |
| | spacing | 0.79 |

4.6.1. Wavelength Plan for 80 Gbps prototype

The values of downstream light wavelengths measured by WDM analyzer immediately after AWG Mux for 80 Gbps TWDM-PON are shown in table 4-8, the same signals from spectrum analyzer are shown in figure 4-22.

Table 4-8: downstream wavelengths – WDM analyzer for 80 Gbps TWDM-PON

| Wavelength (nm) | Signal Power (dBm) |
|-----------------|--------------------|
| 1606.6 | -14.765578 |
| 1605.74 | -14.579551 |
| 1604.88 | -14.38271 |
| 1604.03 | -14.299857 |
| 1603.17 | -14.230466 |
| 1602.31 | -14.363986 |
| 1601.46 | -14.470857 |
| 1600.6 | -14.284898 |

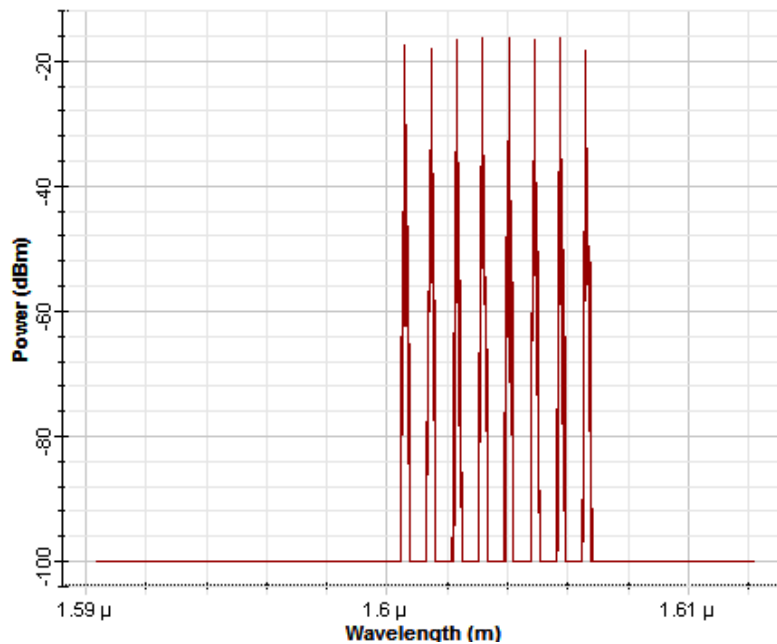

Figure 4-22: downstream wavelengths – spectrum analyzer for 40 Gbps TWDM-PON

The values of upstream light wavelengths measured by WDM analyzer at the connection between SMF cable and first splitter / combiner for 80 Gbps TWDM-PON are shown in table 4-9, the same signals from spectrum analyzer are shown in figure 4-23.

Table 4-9: upstream wavelengths – WDM analyzer for 80 Gbps TWDM-PON

| Wavelength (nm) | Signal Power (dBm) |
|-----------------|--------------------|
| 1535.82 | -25.177604 |
| 1535.04 | -24.405572 |
| 1534.25 | -24.470836 |
| 1533.47 | -24.75143 |
| 1532.68 | -25.323604 |
| 1531.9 | -24.422797 |
| 1531.12 | -24.645621 |
| 1530.33 | -24.308509 |

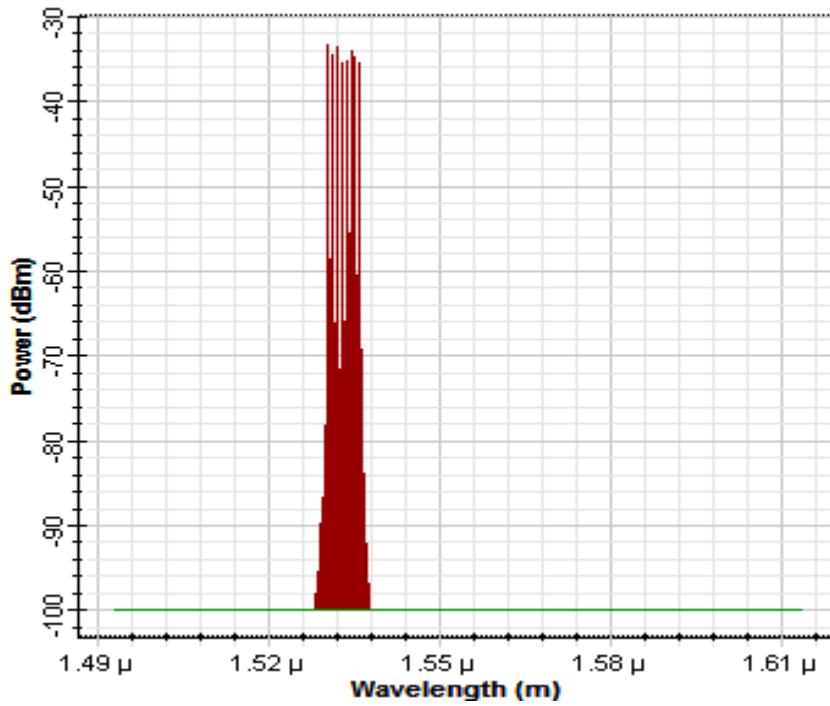

Figure 4-23: upstream wavelengths – spectrum analyzer for 40 Gbps TWDM-PON

4.6.2. Simulation Results (80 Gbps TWDM-PON)

The 80 Gbps TWDM-PON design is also tested for variable parameters that shows good results for feasible implementation for wavelength 1600.6 nm at distance 40Km ; the measured values are 16.1366 Quality Factor (Q-Factor) (see figure 4-26), 6.18×10^{-59} Minimum Bit Error Rate (BER) (see figure 4-27), Eye diagram with opening showing hight and width for good decision of incomming bits conclude that the system downstream is reliable , feasible and can be implemented without any problems..

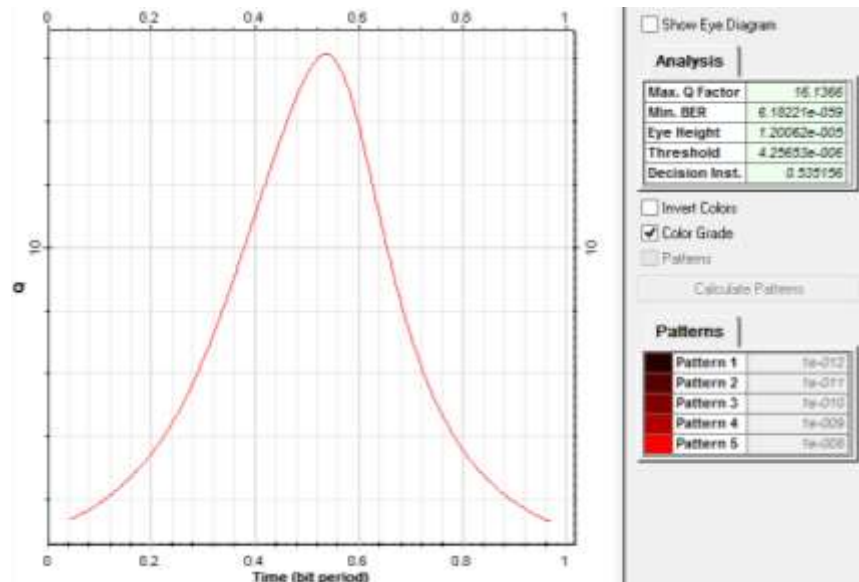

Figure 4-24: Q Factor for 1600.6 nm downstream at 40 Km

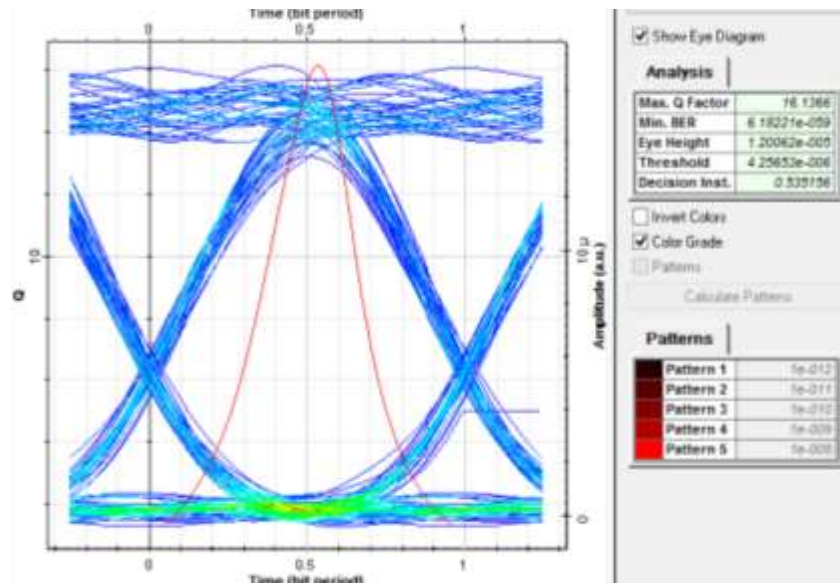

Figure 4-25: Eye Diagram for 1600.6 nm downstream at 40 Km

Figure 4-26 shows the receiver sensitivity for 1600.6 nm wavelength at distances Back to Back (B2B), 10 Km , 20 Km , 30 Km and 40 Km, It is clear that the system has acceptable value of BER at input power of 6 dBm lunched in the OLT transmitter at 40 Km reach while it can be accomplished for less than 40 Km reach with less laser power at OLT transmitter. While figure 4-27 shows that using any of the four wavelengths of transmitted by 80 Gbps TWDM-PON gets almost the same results.

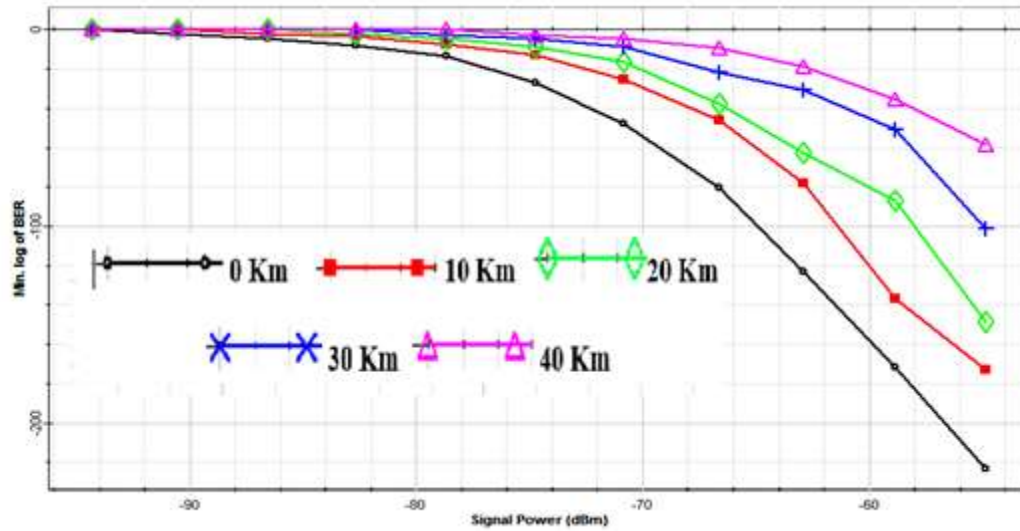

Figure 4-26: Receiver sensitivity for 1600.6 nm

The 80 Gbps TWDM-PON system has the same behavior as 40 Gbps system but it suffers some degradation for the downstream wavelengths 1604.88, 1605.74, 1606.6 nm (see figure 4-27), but the system is still reliable to be implemented with out risk

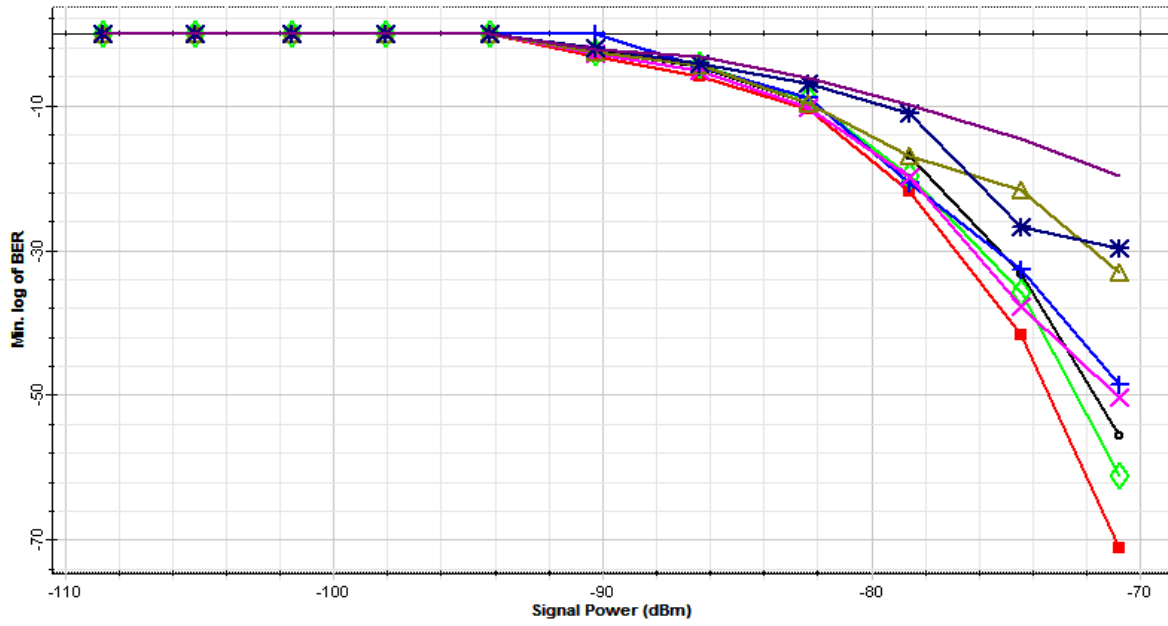

Figure 4-27: Receiver sensitivity at 40 Km

Chapter 5: Conclusion and Future Work

5.1. Conclusion

TWDM NG-PON2 is a promising technology since it offers user requirements for bandwidth and attractive for service providers because of the advantage of saving their investments as TWDM reuses existing distribution network.

TWDM-PON inherits the advantages of PON networks as it does not need power in the distribution planet so it is considered green technology at the same time it reduces the costs of network design, implementation, operation and maintenance.

In this research a TWDM-PON system is designed , implemented and tested using optisystem 13. The results of modular design proved that TWDM-PON has a wide range of advantages that will make it the best solution for next generation optical access networks as it can coexist with previous technologies for smooth upgrade option and can totally replace previous technologies.

The 40 Gbps network can serve 64 users with 640 Mbps dedicated bandwidth for each while the 80 Gbps can serve 128 users with the same user bandwidth. With the power penalty (additional power than required) available the same network design can be extended to either increase the reach distance or duplicate split ratio to increase the number of users sharing the same fiber with minimum risk.

TWDM-PON is transparent technology as it can support variety of MAC address protocol standards.

Throughout this thesis, PON technologies and PON network design was studied in details, each network element is tested over a wide range of parameters for optimum network design.

5.2. Future work

TWDM-PON stir the brain for more study, more experiments much more enhancements especially for fully flexible wavelength and timeslot assignement and management especially for group of users sharing the same wavelength at different distances to study the algorithms of time alignment.

Appendix

Table 0-1: ITU Grid Standard Wavelengths for Dense WDM Systems

| Band | Frequency (THz) | Wavelength (nm) | Spacing (nm) |
|--------|-----------------|-----------------|--------------|
| C-Band | 196.10 | 1528.77 | 0.78 |
| | 196.00 | 1529.55 | |
| | 195.90 | 1530.33 | |
| | 195.80 | 1531.12 | |
| | 195.70 | 1531.90 | |
| | 195.60 | 1532.68 | |
| | 195.50 | 1533.47 | |
| | 195.40 | 1534.25 | |
| | 195.30 | 1535.04 | |
| | 195.20 | 1535.82 | |
| | 195.10 | 1536.61 | |
| | 195.00 | 1537.40 | |
| | 194.90 | 1538.19 | |
| | 194.80 | 1538.98 | |
| | 194.70 | 1539.77 | |
| | 194.60 | 1540.56 | |
| | 194.50 | 1541.35 | |
| | 194.40 | 1542.14 | |
| | 194.30 | 1542.94 | 0.80 |
| | 194.20 | 1543.73 | |
| | 194.10 | 1544.53 | |
| | 194.00 | 1545.32 | |
| | 193.90 | 1546.12 | |
| | 193.80 | 1546.92 | |
| | 193.70 | 1547.72 | |
| | 193.60 | 1548.51 | |
| | 193.50 | 1549.32 | |
| | 193.40 | 1550.12 | |
| | 193.30 | 1550.92 | 0.81 |
| | 193.20 | 1551.72 | |
| | 193.10 | 1552.52 | |
| | 193.00 | 1553.33 | |
| | 192.90 | 1554.13 | |
| | 192.80 | 1554.94 | 0.81 |
| | 192.70 | 1555.75 | |

| Band | Frequency (THz) | Wavelength (nm) | Spacing (nm) |
|--------|-----------------|-----------------|--------------|
| | 192.60 | 1556.55 | |
| | 192.50 | 1557.36 | |
| | 192.40 | 1558.17 | |
| | 192.30 | 1558.98 | |
| | 192.20 | 1559.79 | |
| | 192.10 | 1560.61 | |
| | 192.00 | 1561.42 | |
| | 191.90 | 1562.23 | |
| | 191.80 | 1563.05 | |
| | 191.70 | 1563.86 | |
| | 191.60 | 1564.68 | |
| | 191.50 | 1565.50 | |
| | 191.40 | 1566.31 | |
| | L-band | 191.30 | |
| 191.20 | | 1567.95 | |
| 191.10 | | 1568.77 | |
| 191.00 | | 1569.59 | |
| 190.90 | | 1570.42 | |
| 190.80 | | 1571.24 | |
| 190.70 | | 1572.06 | |
| 190.60 | | 1572.89 | |
| 190.50 | | 1573.71 | |
| 190.40 | | 1574.54 | |
| 190.30 | | 1575.37 | 0.83 |
| 190.20 | | 1576.20 | |
| 190.10 | | 1577.03 | |
| 190.00 | | 1577.86 | |
| 189.90 | | 1578.69 | |
| 189.80 | | 1579.52 | |
| 189.70 | | 1580.35 | |
| 189.60 | | 1581.18 | |
| 189.50 | | 1582.02 | |
| 189.40 | | 1582.85 | |
| 189.30 | | 1583.69 | 0.84 |
| 189.20 | | 1584.53 | |
| 189.10 | | 1585.36 | |
| 189.00 | | 1586.20 | |
| 188.90 | | 1587.04 | |
| 188.80 | | 1587.88 | |
| 188.70 | | 1588.73 | |

| Band | Frequency (THz) | Wavelength (nm) | Spacing (nm) |
|------|-----------------|-----------------|--------------|
| | 188.60 | 1589.57 | |
| | 188.50 | 1590.41 | |
| | 188.40 | 1591.26 | |
| | 188.30 | 1592.10 | 0.85 |
| | 188.20 | 1592.95 | |
| | 188.10 | 1593.79 | |
| | 188.00 | 1594.64 | |
| | 187.90 | 1595.49 | |
| | 187.80 | 1596.34 | |
| | 187.70 | 1597.19 | |
| | 187.60 | 1598.04 | |
| | 187.50 | 1598.89 | |
| | 187.40 | 1599.75 | |
| | 187.30 | 1600.60 | |
| | 187.20 | 1601.46 | 0.86 |
| | 187.10 | 1602.31 | |
| | 187.00 | 1603.17 | |
| | 186.90 | 1604.03 | |
| | 186.80 | 1604.88 | |
| | 186.70 | 1605.74 | |

References

- [1] Santa Clara, Calif. "<http://www.fsan.org>" , FSAN News, July 16, 2012
- [2] D. Nowak and J. Murphy, "FTTH: The Overview of Existing Technologies",
- [3] Gerd Keiser, "*Optical Fiber Communications*", 5th ed., McGraw-Hill, 2014.
- [4] Mynbaev, D. K., Scheiner, L. L. "Fiber Optic Communications Technology", New Jersey: Prentice Hall. 2001
- [5] http://en.wikipedia.org/wiki/Passive_optical_network
- [6] DeCUSATIS, C. Handbook of Fiber Optics Data Communication, A Practical Guide to Optical Networking. 4th ed. Academic Press, 2013.
- [7] M. Hajduczenia, and H. da Silva, "Next Generation PON Systems - Current Status," Int. Conf. Transparent, Optical Networks, France., 2009, pp. 1
- [8] Kani, J , Next-generation PON- Part I: Technology Roadmap and General Requirements , IEEE Communications magazine, 2009 , vol , no , p.43 – 49.
- [9] Santa Clara, Calif. "<http://www.fsan.org>" , FSAN News, July 16, 2012.
- [10] "Evolution of FTTH Networks for NG-PON2", PT Inovacoo White Paper 2013.
- [11] CISCO VNI Global Forecast 2011-2016.
- [12] website: www.ad-net.com.tw.
- [13] website: <http://optiwave.com>.
- [14] Optical Fibers Cables and Systems , ITU-T Manual 2009
- [15] Chinlon Lin, Broadband Optical Access Networks and Fiber-to-the-Home, Wiley, 2006.
- [16] Broadband Technology Overview, White Paper, WP6321, Issued: June 2005
- [17] Josep Prat "Next-Generation FTTH Passive Optical Networks" Springer.2008.
- [18] G. P. Agrawal, Fiber-Optic Communication Systems, 3rd ed. New York: Wiley, 2002
- [19] Guo, Y., Kao, C. K. and Chiang, K. S. "Nonlinear photonics: nonlinearities in optics, optoelectronics and fiber communications." Springer -Verlag, 2002. Berlin, Germany.
- [20] ITU-T manual 2009, Optical fibre, cables and systems

- [21] CASIMER DeCUSATIS ,FIBER OPTIC DATA COMMUNICATION:TECHNOLOGICAL TRENDS AND ADVANCES, Academic Press 2002
- [22] Optisystem 13 Help
- [23] Arrayed Waveguide Gratings, Research Center for Microtechnology, tiny structure for big ideas, FHV research, DWDM 5-2010
- [24] Elaine Wong, Next Generation Broadband Access Network and Technologies, Journal of Lightwave Technology 2012.
- [25] Jingjing Zhang, Media Access Control and Resource Allocation , For Next Generation Passive Optical Networks, springer 2013
- [26] Jani Saheb Shaik, FTTH Deployment Options for Telecom Operators, Sterlite Optical Technologies Ltd
- [27] website: <http://www.nationalfiberconnections.com/gpon-olt.html>
- [28] P. M. D. Indonesia, 2014. [Online]. Available: <http://dasannetworksid.com/v8500>.
- [29] International Telecommunication Union (2001). Broadband optical access systems based on Passive Optical Networks (PON).ITU-T Recommendation G.983.1
- [30] website : <http://www.nationalfiberconnections.com/gpon-olt.html>
- [31] Keiser, Gerd (2006). FTTH concepts and applications, John Wiley & Sons, Inc.
- [32] dasan, 2012. [Online]. Available: <http://dasannetworks.eu/en/gpon-ont-outdoor---h695/46/>.
- [33] website, www.jdsu.com/fttx, Understanding Passive Optical Network Testing
- [34] website: <http://online-telecom-exhibition.blogspot.com/>
- [35] website: <http://www.exfiber.com/tutorial/How-does-a-PLC-Splitter-work-13.html>
- [36] website: <http://www.thefoa.org/tech/ref/testing/test/couplers.html>
- [37] Glen Kramer "Ethernet Passive Optical Networks", 1st Edition, McGraw-Hill 2005
- [38] K. Grobe and J. P. Elbers "PON in adolescence: from TDMA to WDM-PON" IEEE Communications Magazine., vol.46, no.1, pp.26–34, Jan.2008.
- [39] website: <http://www.telcordia.com/services/testing/integrated-access/pon/>

- [40] Alex Vukovic, Khaled Maamoun, Heng Hua, Michel Savoie, Performance Characterization of PON Technologies, Broadband Applications and Optical Networks, Communications Research Centre (CRC), Ottawa, ON, Canada, K2H 8S2
- [41] Ivan P. Kaminow " Optical Fiber Telecommunications V B Systems and Networks ", 1st Edition, Elsevier 2008.
- [42] ITU-T Recommendation G.652
- [43] Ethernet in the First Mile, IEEE 802.3 Study Group
- [44] Anwar Walid and Aiyou Chen, Self-Adaptive Dynamic Bandwidth Allocation for GPON, Bell Labs Technical Journal 2010
- [45] Achyut K. Dutta, WDM TECHNOLOGIES: ACTIVE OPTICAL COMPONENTS, Academic Press 2012.
- [46] Huawei Technologies "Next-Generation PON Evolution" Huawei Technologies 2010
- [47] Zheng xuan li, experimental demonstration of symmetric 40-Gb/s TWDM-PON, OFC/NFOFC technical digest 2013.
- [48] CEDRIC F. LAM, Passive Optical Networks Principles and Practice, Elsevier 2007.
- [49] Elaine Wong, Michael Mueller and Markus C. Amann, Characterization of energy-efficient and colorless ONUs for future TWDM-PONs.
- [50] Varun Marwaha, Review of Passive Optical Network , International Journal of the Latest Transations in Engineering and Science (IJLTES).
- [51] Yuanqiu Luo, Wavelength Management in Time and Wavelength Division Multiplexed Passive Optical Networks (TWDM-PONs), Globecom, 2012.
- [52] Stamatios v. Kartalopoulos, "INTRODUCTION TO DWDM TECHNOLOGY" Wiley-IEEE Press , 2000
- [53] Yuanqiu Luo, Xiaoping Zhou, Frank Effenberger, Xuejin Yan, Guikai Peng, Yinbo Qian and Yiran Ma, "Time- and Wavelength-Division Multiplexed Passive Optical Network (TWDM-PON) for Next-Generation PON Stage 2 (NG-PON2)" JOURNAL OF LIGHTWAVE TECHNOLOGY, VOL. 31, NO. 4, FEBRUARY 15, 2013
- [54] Yuanqiu Luo, NFOEC workshop: Technologies for NG-PON2: Why I Think This Technology Is the Clear Winner.
- [55] Marija D. Markovic, Analysis of coexisting GPON and NG-PON1 (10G-PON) systems, telfor journal VOL.3, NO.1, 2011.